





ABOUT COMPANY

COOPER&HUNTER – Feel the comfort.

With more than 20 years experience in air conditioning and ventilation, Cooper&Hunter has grown into a leading HVAC market player. Products under the Cooper&Hunter brand are exported to more than 30 countries and regions around the world. Since becoming involved in overseas markets, Cooper&Hunter has developed into a well-known brand with rapid growth in export sales volume, adding new markets every year.

In 2017 the company has entered into definitive agreements for a long-term strategic partnership with Zhuhai Vinto Environmental Technology Equipment Co. LTD and company stock share purchase that is expected to accelerate another company growth on the global market. Factory in Zhuhai received new name: Zhuhai Vinto – Cooper&Hunter Environmental Technology Equipment Co. LTD.

Our quality, reliable products can be certified by most major international testing standards in the USA, Canada, and the European Union. We are dedicated to technological innovation and consumer-driven product development. Our R&D team continues to generate new products that adhere to the highest quality standards, providing reliable, energy-efficient, and cost-effective air conditioning solutions. As we implement innovations, we take into account both the needs of current customers and future engineering trends. We have combined the latest elegant ergonomic designs with comfort and high-quality modern technology. We are focused on constant improvement and providing the best service possible. We commit to producing quality products that improve our customers' lives.

Cooper&Hunter is making hot places cool and cool places more pleasant, bringing COMFORT INNOVATIONS to every home and business!

CISION

Cooper&Hunter
Becomes an Official
HVAC Partner of
the Florida Panthers



CISION CISION

www.cision.com

THOMSON REUTERS

CISION CISION

www.cision.com

at&t

europa cafe
europa cafe
europa cafe



Welcome to Cooper&Hunter Business Portal

This business portal is intended for dealers and business partners of "Cooper&Hunter". "Cooper&Hunter" – is a modern-tech brand, we appreciate our partners and support them with continuous communications.

Here you will find the information necessary for the successful sale of TM C&H:

- promotional materials (catalogs, brochures, layouts, samples, corporate identity, commercials video)
- technical manuals (user manuals, datasheets, certificates)
- detailed information for engineers and installers about the maintenance, and troubleshooting (technical catalogs, videos)

- on individual page, the dealer can see the personal commercial information, a list of equipment ready for sale and place a pre-order.

The list of services on our business portal is constantly growing. We are always ready to listen and implement Your requests. Please apply in writing (portal@cooperandhunter.com).

Support of COOPER&HUNTER INTERNATIONAL CORPORATION

*only to the registered dealers (the 1st level)

www.ch-business.com

Cooper&Hunter Comfort Innovations I-Action Inverter Technology

C&H inverters are hi-tech systems controlled by the innovative built-in microprocessor based on unique technology I-Action Inverter Technology.

This means that the rotor compressor achieving the specified

temperature does not turn off and continues to work at the extremely low 1 Hz frequency consuming only 40 watt/hour. Thus Cooper&Hunter saves up to 50% of consumed electric power and extends the service period up to 10 years.

Advantages of I-Action Technology:



Extremely low frequency of compressor rotation

- Accurate temperature control
- Saves up to 40% of the electric power supply



Refrigerant R410A

- Ozone-safe
- Effective cooling

Refrigerant R32

- Low Global Warming Potential (GWP)
- Zero Ozone Depleting Potential (ODP)



Strain automatic adjustment (150-265 V)

- Stable work at power supply voltage swing
- Avoidance of damage

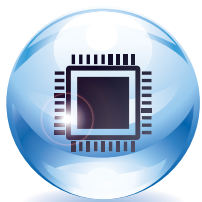

Modern high-speed microprocessor

- High functional control
- Effective control of parameters



Noiseless operation

- from 25 dB in the room
- Provides quiet and comfort



Performance reliability

- Quality control at all production stages
- Perfect characteristics and high capacity



Strict temperature control

- Accuracy in the air temperature control up to 0,1°C
- Control of the specified parameters



Turbo mode

- High-speed achievement of the necessary temperature
- Quick cooling and space heating



Continuous operation

- Operates in the modes from maximum to minimum without the turn off
- Saves the electric energy



THE PHYSICAL PROPERTIES OF FREON R32 AND R410A ARE VERY CLOSE. IT ALLOWS TO USE COPPER TUBES AND OILS WITH THE SAME CHARACTERISTICS LIKE IN R410A DEVICES AS WELL AS R32 EQUIPMENT.

HAVING EQUAL PRODUCTIVITY THE LOWER DENSITY OF THE NEW REFRIGERANT MAKES IT POSSIBLE TO SAVE ON THE AMOUNT OF R32 (SAVING BY 29%).

LOW VISCOSITY MEANS THAT THE PRESSURE LOSS IN THE ELEMENTS OF THE REFRIGERATION CIRCUIT IS REDUCED. THIS INCREASES THE OVERALL ENERGY EFFICIENCY BY ABOUT 5%. THE THERMAL CONDUCTIVITY OF R32 IS HIGHER THAN THAT OF R410A, WHICH MAKES IT POSSIBLE TO INCREASE THE COOLING CAPACITY PER UNIT MASS BY ABOUT

4% AND AT THE SAME TIME TO REDUCE THE POWER CONSUMPTION OF THE DEVICE BY 10%.

AS A SINGLE COMPONENT, FREON R32 HAS THE ABILITY TO REFUEL REGARDLESS OF THE AMOUNT OF REFRIGERANT IN THE CIRCUIT. OPERATION WITH R32 IS MUCH SIMPLER THAN WITH THE TWO-COMPONENT R410A.

THE GLOBAL WARMING POTENTIAL OF R32 IS 67% LOWER THAN THAT OF THE MORE COMMON R410A REFRIGERANT AND THAT IS ULTIMATELY SAFER FOR THE ENVIRONMENT.

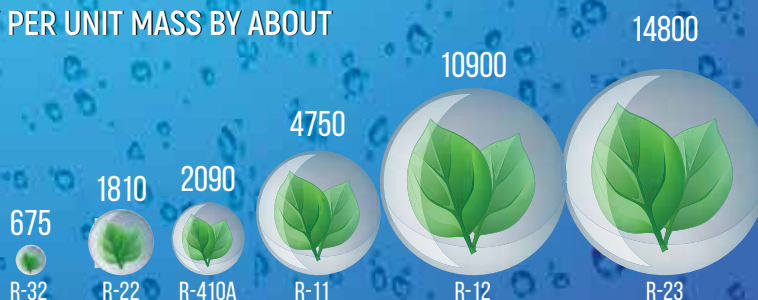

THE GLOBAL WARMING POTENTIAL

Comparison of inverter with the standard air conditioner

How does an inverter save energy?

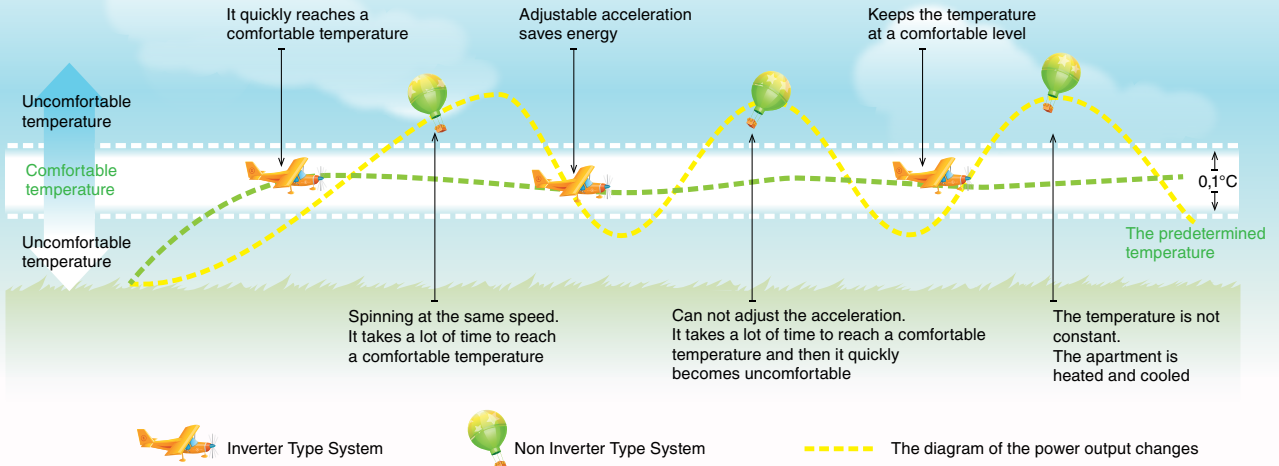

Three components of efficiency

1 VENTILATION

The air conditioner has an upgraded built-in axial ventilator of the external unit with bigger diameter and an indoor unit powerful ventilator to increase the air capacity and improve the efficiency of heat exchanger.

2 CONTROL

Noiseless built-in microprocessor, which controls the heart of air conditioner. Operates in the modes from maximum to minimum without the turn off, saves up to 40% of the electric energy, extends the equipment service up to 10 years.

3 COOLING

Highly effective and stable operating compressor. The heat exchanger has an improved pipe system. High-performance electronic expansion valve strictly controls the refrigerant flow.

Proper operation



Self-cleaning indoor unit

After the operation is over, the ventilator blows off and dries the air conditioner from the inside to avoid moisture, fungi and corrosion.



Self-diagnosis

Helps to keep the air conditioner in perfect state and immediately detects problems. The code appears on the control panel to notify about the problem.



Restart function

This is the possibility to restore all operation parameters in case of the accidental powercut.



Integrated device

Special base and water basin in the indoor unit help to avoid a leakage and reduce the noise level.



Voltage variation protection

Automatically adjusts to voltage variation (150-265 V), provides stable operation and allows to prevent a crash.



Fireproof box

The electric box in the metal case provides the safety and fire protection. Prevents an ignition in case of short circuit.

Smart Inverter. Save up to 40% of energy!

Heating at -30°C with heating capacity improved by 40%

Strong cooling at +54°C with cooling capacity improved by 25%

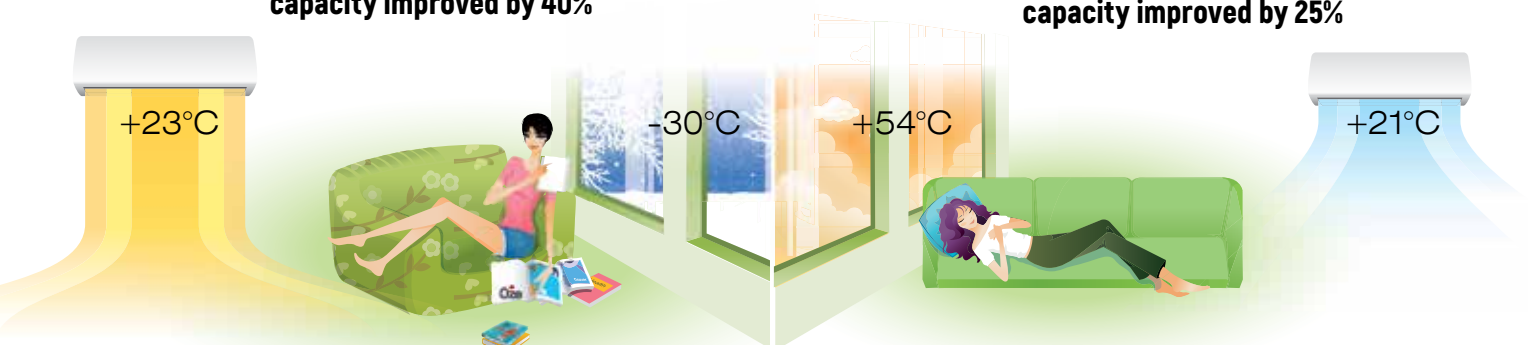

Our progress

Sales Growth Trend (% growth/year)

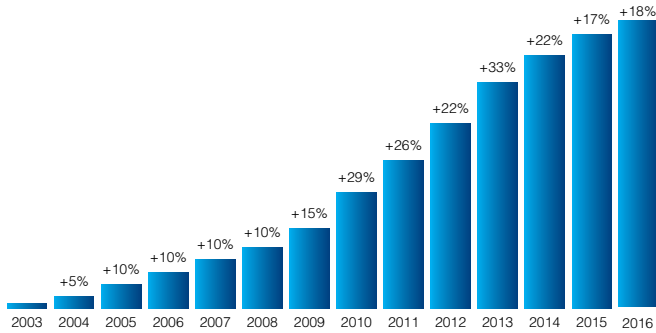

Total growth 217%

Each series of COOPER&HUNTER products has its unique features, wide range of functions and gorgeous appearance.

COOPER&HUNTER equipment is the harmony of the engineering innovations and creative ideas, which provides comfort and suitable indoor climate for the everyday life.

Working with COOPER&HUNTER, you always have access to the latest innovations in the sphere of the climate control equipment with unchangeably high quality, modern design and style.

Product Failure Rate Trend.

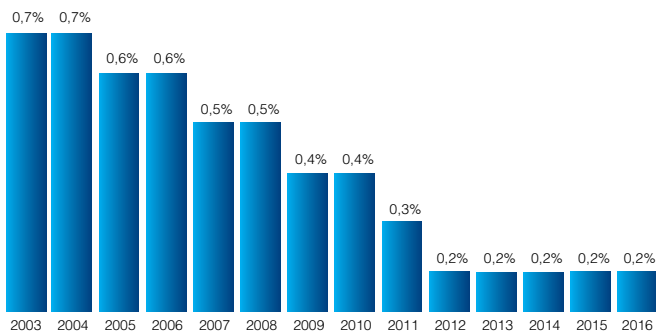

*According to the data of the authorized service centers, statistics of refusal since 2012 makes less than 0,2%.

Product failure rate has decreasing tendency during last 13 years. Cooper&Hunter is proudly stands behind the products with 7-year warranty for compressors and 5-year warranty for parts. All major parts are available at the main logistics hubs as well as at major distributors' warehouses

Quality control standards C&H meet the requirements American Society of Heating, Refrigerating Air-Conditioning Engineers (ASHRAE). American Association of engineers for heating, refrigeration and air conditioning.

Range of products

Household, commercial, industrial air conditioning systems of all types, specialized air conditioners (nautical, for telecommunications etc.)

- Household and industrial air conditioners
- Household humidifiers, air cleaners
- Household coolers, purifiers, water purification systems
- Household electric heaters
- Household and industrial energy-saving heat pumps
- Air curtains



Cooper&Hunter equipment is produced under high standards and requirements of the USA, Canada and European Union. C&H has become a mark of quality and reliability of HVAC equipment. The company's goal has always been to give the customers the best quality air conditioners for an affordable price.



Is the member of USHP (Unitary Small Heat Pump Equipment /includes Mix-Match Coils/) certification program AHRI (Air Conditioning, Heating and Refrigeration Institute).



Has the European Commission mark which confirms the correspondence to requirements for health, safety and ecology. Allows distribution of Cooper&Hunter products within the internal EU market.



ETL certificate confirms the correspondence of Cooper&Hunter products to the safety and quality standards in the USA and Canada.



"I feel" function

The function controls the air temperature by means of the detector on the control panel. The temperature detector measures air temperature at the place and transfers the information to the air conditioner indoor unit. "I feel" adjusts in such way to achieve necessary parameters of climate comfort directly where the remote is.

Intelligent defrost

Is more effective heating function. Contrary to the previous programs, old models, the "intelligent defrost" program activates the process if only it is really necessary.

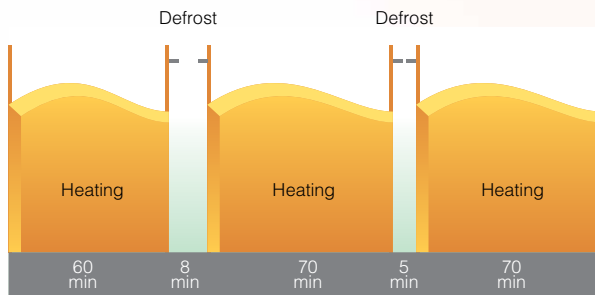

Intelligent defrost Cooper&Hunter

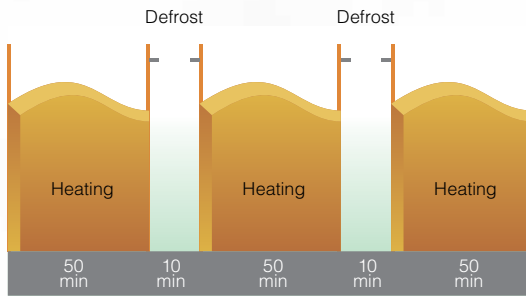

Traditional defrost

Comfort for life



Intelligent defrost is more effective heating function. Contrary to the previous programs and old models, the "Intelligent defrost" program activates the process if only it is really necessary.



Hot start the air conditioner turns off only after the necessary air temperature is achieved.



Control panel lock defends from the undesirable control.



Turbo mode is a quick and powerful function to achieve the necessary temperature.



Night mode very quiet operation and support of comfort temperature during the night.



"I feel" function provides personalised environment since the temperature can be detected where the remote controller is located.

SUPREME SERIES

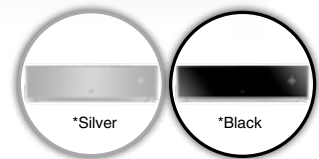

Two-stage Compressor



- Bigger structure for better performance and higher efficiency;
- Elegant LED display, hidden when the unit is off;
- Operating temperature range: cooling from -18°C to +54°C, heating from -30°C to +24°C.



Model	CH-S09FTXAM2S-SG CH-S09FTXAM2S-GD CH-S09FTXAM2S-BL		CH-S12FTXAM2S-SG CH-S12FTXAM2S-GD CH-S12FTXAM2S-BL		CH-S18FTXAM2S-SG CH-S18FTXAM2S-GD CH-S18FTXAM2S-BL		CH-S24FTXAM2S-SG CH-S24FTXAM2S-GD CH-S24FTXAM2S-BL	
	Capacity	Cold	kW	2,70 (0,70-5,00)	3,53 (0,85-5,00)	5,30 (1,20-7,20)	7,03 (2,00-9,00)	7,03 (2,00-9,00)
	Warm	kW	3,50 (0,70-5,50)	4,20 (0,88-7,20)	5,57 (1,20-9,20)	7,03 (2,00-9,50)	7,03 (2,00-9,50)	7,03 (2,00-9,50)
Electric power supply	- 220-240V/50Hz							
Rated input	Cold	kW	0,55 (0,08-1,80)	0,84 (0,06-1,90)	1,32 (0,35-2,50)	1,85 (0,45-3,70)	1,85 (0,45-3,70)	1,85 (0,45-3,70)
	Warm	kW	0,75 (0,13-2,40)	0,95 (0,13-2,60)	1,32 (0,35-3,30)	1,75 (0,38-3,80)	1,75 (0,38-3,80)	1,75 (0,38-3,80)

INDOOR UNIT

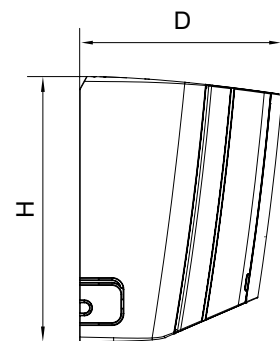
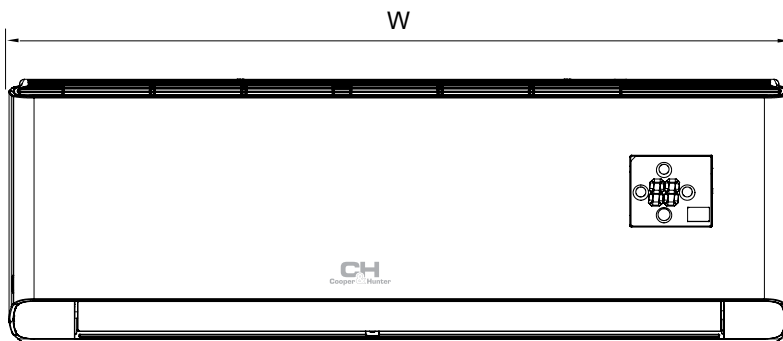

Model	W (mm)	H (mm)	D (mm)
CH-S09FTXAM2S-SG/ CH-S09FTXAM2S-GD/ CH-S09FTXAM2S-BL	996	301	225
CH-S12FTXAM2S-SG/ CH-S12FTXAM2S-GD/ CH-S12FTXAM2S-BL	996	301	225
CH-S18FTXAM2S-SG/ CH-S18FTXAM2S-GD/ CH-S18FTXAM2S-BL	1101	327	249
CH-S24FTXAM2S-SG/ CH-S24FTXAM2S-GD/ CH-S24FTXAM2S-BL	1101	327	249

OUTDOOR UNIT

CH-S09FTXAM2S-SG
CH-S09FTXAM2S-GD
CH-S09FTXAM2S-BL

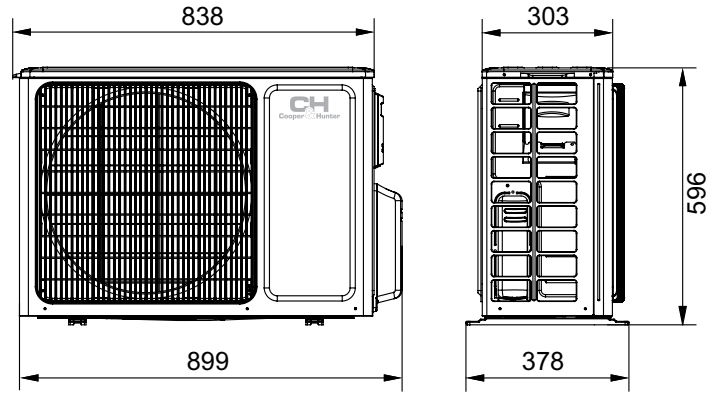
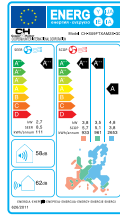

CH-S12FTXAM2S-SG
CH-S12FTXAM2S-GD
CH-S12FTXAM2S-BL

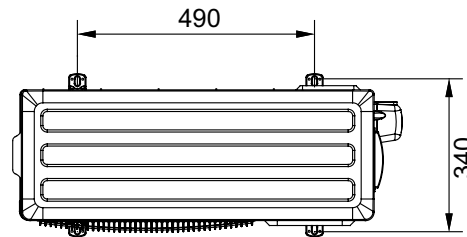
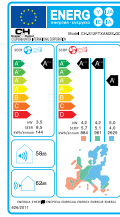

CH-S18FTXAM2S-SG
CH-S18FTXAM2S-GD
CH-S18FTXAM2S-BL

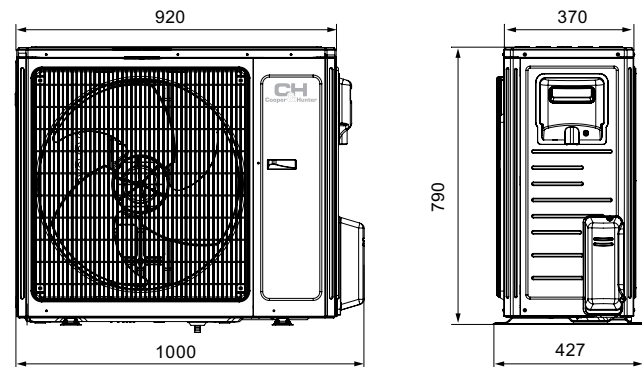
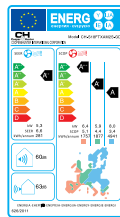

CH-S24FTXAM2S-SG
CH-S24FTXAM2S-GD
CH-S24FTXAM2S-BL

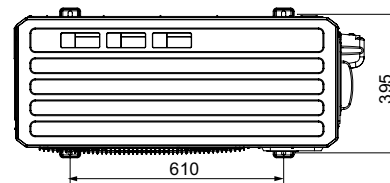

Model	CH-S09FTXAM2S-SC CH-S09FTXAM2S-GD CH-S09FTXAM2S-BL		CH-S12FTXAM2S-SC CH-S12FTXAM2S-GD CH-S12FTXAM2S-BL		CH-S18FTXAM2S-SC CH-S18FTXAM2S-GD CH-S18FTXAM2S-BL		CH-S24FTXAM2S-SC CH-S24FTXAM2S-GD CH-S24FTXAM2S-BL	
	Capacity	Cold	kW	2,70 (0,70-5,00)	3,53 (0,85-5,00)	5,30 (1,20-7,20)	7,03 (2,00-9,00)	
	Warm	kW	3,50 (0,70-5,50)	4,20 (0,88-7,20)	5,57 (1,20-9,20)	7,03 (2,00-9,50)		
Electric power supply			-220-240V/50Hz					
Rated input	Cold	kW	0,55 (0,08-1,80)	0,84 (0,06-1,90)	1,32 (0,35-2,50)	1,85 (0,45-3,70)		
	Warm	kW	0,75 (0,13-2,40)	0,95 (0,13-2,60)	1,32 (0,35-3,30)	1,75 (0,38-3,80)		
Seasonal system performance factor	SEER (cooling)	kW / kW	8,5 (A+++)	8,5 (A+++)	6,6 (A++)	6,5 (A++)		
	SCOP (heating)	kW / kW	5,1 (A+++)	5,1 (A+++)	4,4 (A+)	4,1 (A+)		
Air productive capacity		m ³ /h	430/500/560/620/670/720/800	450/530/580/630/680/730/800	600/780/950/1150/1200	650/750/800/850/950/1100/1250		
Sound-pressure level	indoor unit	dB (A)	18/22/26/30/34/38/43	20/24/28/32/36/41/46	30/33/36/39/42/45/48	32/35/38/41/44/47/50		
	outdoor unit	dB (A)	53	54	56	56		
Type of refrigerant coolant			R-32					
Weight	indoor unit	kg	13	13,5	16,5	16,5		
	outdoor unit	kg	44,5	45,5	62,5	65		
Compressor type			rotary					
Drainage		l/h	0,8	1,4	1,8	2,0		
Temperature range	cooling	°C	-18 ... +54					
	heating	°C	-30 ... +24					
Weight of refrigerant coolant		kg	1,0	1,0	1,5	2,0		
Liquid pipeline diameter		mm/inch	6,38/1/4"	6,38/1/4"	6,38/1/4"	6,38/1/4"		
Gas pipeline diameter		mm/inch	9,53/3/8"	9,53/3/8"	15,88/5/8"	15,88/5/8"		
Maximum pipeline level difference		m	10	20	20	30		
Pipeline maximum length		m	15	40	40	50		
Distance between the bolts of the outdoor unit fastening		mm	550		610		760	

* SEER – Seasonal Energy Efficient Rating in the cooling mode. ** SCOP – seasonal system capacity ratio in the heating mode.



Two-stage
Compressor



- A new double stage inverter compressor provides effective operation in the temperature range: cooling from -15°C to +54°C, heating from -30°C to +24°C;
- Noiseless operation of the indoor unit 20 dB (A);
- Wi-Fi module to control the air conditioner using the smartphone/tablet (OS: Android).



Model		CH-S09FTXTB2S-W	CH-S12FTXTB2S-W	CH-S18FTXTB2S-W	CH-S24FTXTB2S-W
Capacity	kW Cold	2.60 (0.76-4.81)	3.50(0.74-4.73)	5.28(1.00-6.30)	7.00(2.00-8.60)
	kW Warm	3.00 (0.82-5.50)	3.65(0.83-6.33)	5.45(1.00-7.14)	7.00(1.90-9.00)
Power intake	kW Cold	0.60 (0.20-1.10)	0.81(0.22-1.30)	1.32(0.38-2.45)	1.92(0.40-3.70)
	kW Warm	0.65 (0.21-1.60)	0.79(0.39-1.90)	1.20(0.40-2.50)	1.79(0.45-3.70)

INDOOR UNIT

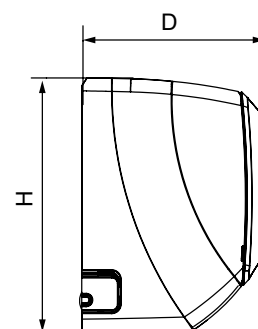
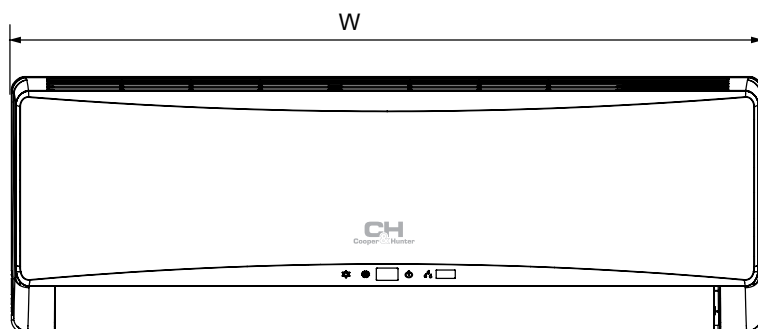

Model	W (mm)	H (mm)	D (mm)
CH-S09FTXTB2S-W	866	292	209
CH-S12FTXTB2S-W	866	292	209
CH-S18FTXTB2S-W	1018	319	230
CH-S24FTXTB2S-W	1178	326	264

OUTDOOR UNIT

CH-S09FTXTB2S-W
CH-S12FTXTB2S-W

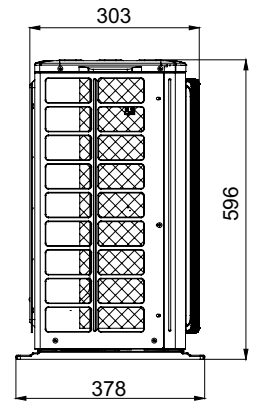
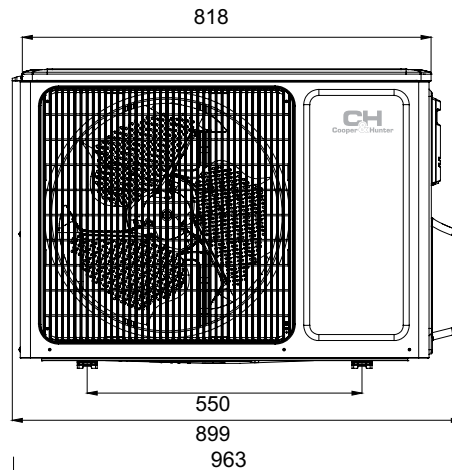
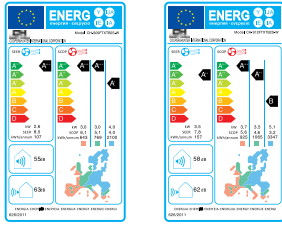

CH-S18FTXTB2S-W

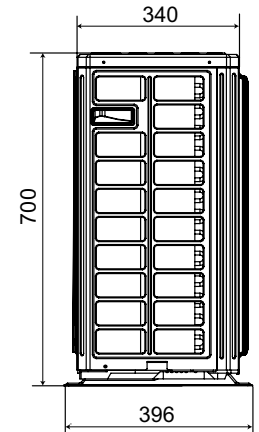
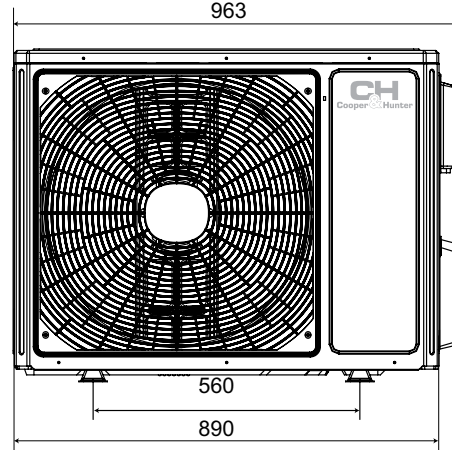
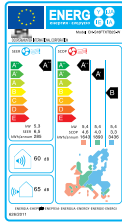

CH-S24FTXTB2S-W

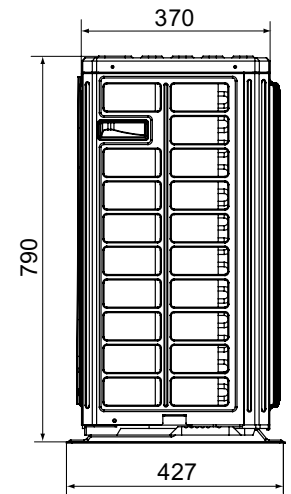
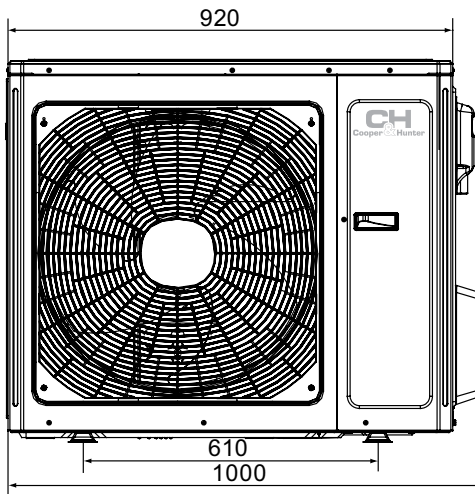
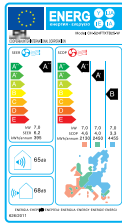

Model		CH-S09FTXTB2S-W	CH-S12FTXTB2S-W	CH-S18FTXTB2S-W	CH-S24FTXTB2S-W	
Capacity	Cold	kW	2.60 (0.76-4.81)	3.50 (0.74-4.73)	5.28 (1.00-6.30)	7.00 (2.00-8.60)
	Warm	kW	3.00 (0.82-5.50)	3.65 (0.83-6.33)	5.45 (1.00-7.14)	7.00 (1.90-9.00)
Electric power supply				- 220-240V/50Hz/1Ph		
Rated input	Cold	kW	0.60 (0.20-1.10)	0.81 (0.22-1.30)	1.32 (0.38-2.45)	1.92 (0.40-3.70)
	Warm	kW	0.65 (0.21-1.60)	0.79 (0.39-1.90)	1.20 (0.40-2.50)	1.79 (0.45-3.70)
Energy performance	EER (Cold)/COP (Warm)	kW/kW	4.33/4.62	4.30/4.60	4.00/4.55	3.64/3.90
SEER*/SCOP** (energy performance class)			8.5 (A+++)/5.1 (A+++)	7.8 (A++)/4.6 (A++)	6.5 (A+)/4.0 (A+)	6.2 (A+)/4.0 (A+)
Air productive capacity		m ³ /h	350/400/450/500/550/600/650	380/410/460/530/610/670/740	480/560/630/710/790/870/950	780/850/920/990/1060/1130/1200
Sound-pressure level	indoor unit	dB (A)	20/24/28/32/34/36/43	20/24/28/32/34/36/43	30/34/38/40/42/44/46	32/37/42/44/46/50/51
	outdoor unit	dB (A)	54	55	56	58
Type of refrigerant coolant				R410A		
Weight	indoor unit	kg	11/41	11/43,5	14/51	17/65
	outdoor unit	kg				
Compressor type				rotor		
Drainage		l/h	0.8	1.4	1.8	2.5
Operational temperature range cooling		°C			-15/+54	
Operational temperature range heating		°C			-30/+24	
Weight of refrigerant coolant		kg	1.20	1.30	1.65	2.00
Liquid pipeline diameter		mm/inch	6.38/1/4"	6.38/1/4"	6.38/1/4"	6.38/1/4"
Gas pipeline diameter		mm/inch	9.53/3/8"	12.7/1/2"	15.88/5/8"	15.88/5/8"
Maximum pipeline level difference		m	10	10	10	10
Pipeline maximum length		m	15	20	25	25

* SEER – Seasonal Energy Efficient Rating in the cooling mode. ** SCOP – seasonal system capacity ratio in the heating mode.

ARCTIC INVERTER SERIES



INVERTER



- Household heat pump. Designed to provide warmth to the northern countries
- Operating temperature range: cooling from -15°C to +48°C, heating from -25°C to +24°C
- Continuous operation in the range of 96 V-260V.
- The innovative, compact transformer



Model		CH-S09FTXLA (Wi-Fi)	CH-S12FTXLA (Wi-Fi)	CH-S18FTXLA (Wi-Fi)	CH-S24FTXLA (Wi-Fi)
Capacity	Cold kW	2,60 (0,44-3,26)	3,50 (0,60-4,05)	5,13 (1,05-6,50)	6,70 (1,50-7,00)
	Warm kW	2,80 (0,44- 4,20)	3,67 (0,60-5,25)	5,275 (1,00-7,00)	7,25 (1,20-7,80)
Power intake	Cold kW	0,59 (0,20-1,35)	0,80 (0,22-1,45)	1,28 (0,36-2,50)	1,56 (0,35-2,50)
	Warm kW	0,61(0,20-1,45)	0,79(0,22-1,55)	1,16(0,35-2,60)	1,73 (0,35-2,70)

INDOOR UNIT

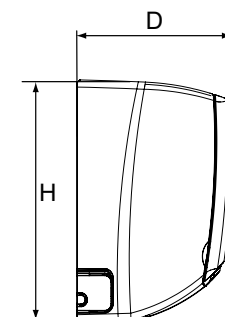
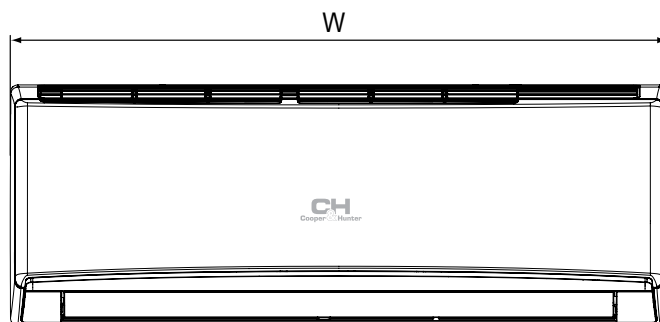

Model	W (mm)	H (mm)	D (mm)
CH-S09FTXLA (Wi-Fi)	790	275	200
CH-S12FTXLA (Wi-Fi)	845	289	209
CH-S18FTXLA (Wi-Fi)	970	300	224
CH-S24FTXLA (Wi-Fi)	1078	325	246

OUTDOOR UNIT

CH-S09FTXLA (Wi-Fi)
CH-S12FTXLA (Wi-Fi)

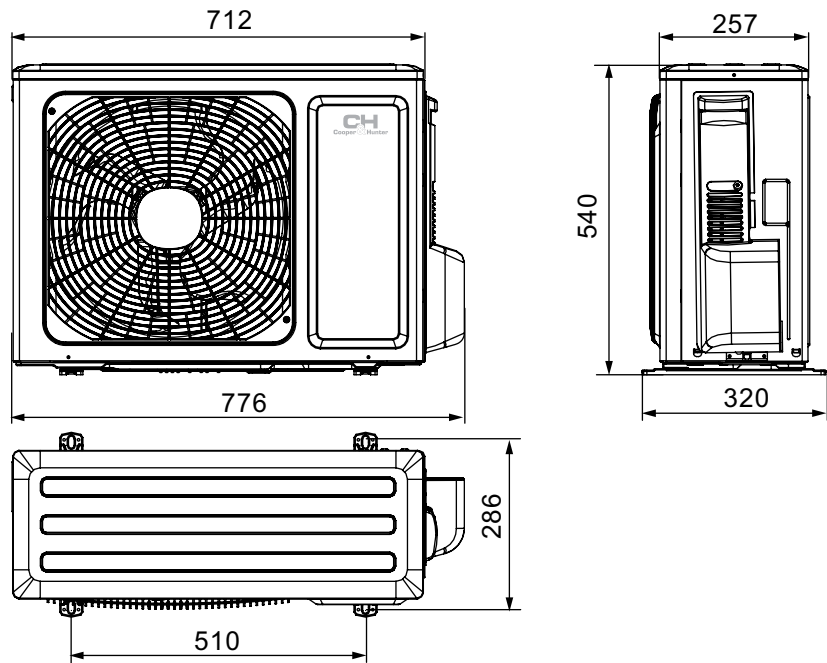
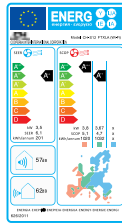
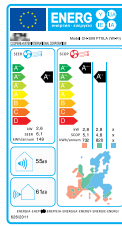

CH-S18FTXLA (Wi-Fi)
CH-S24FTXLA (Wi-Fi)

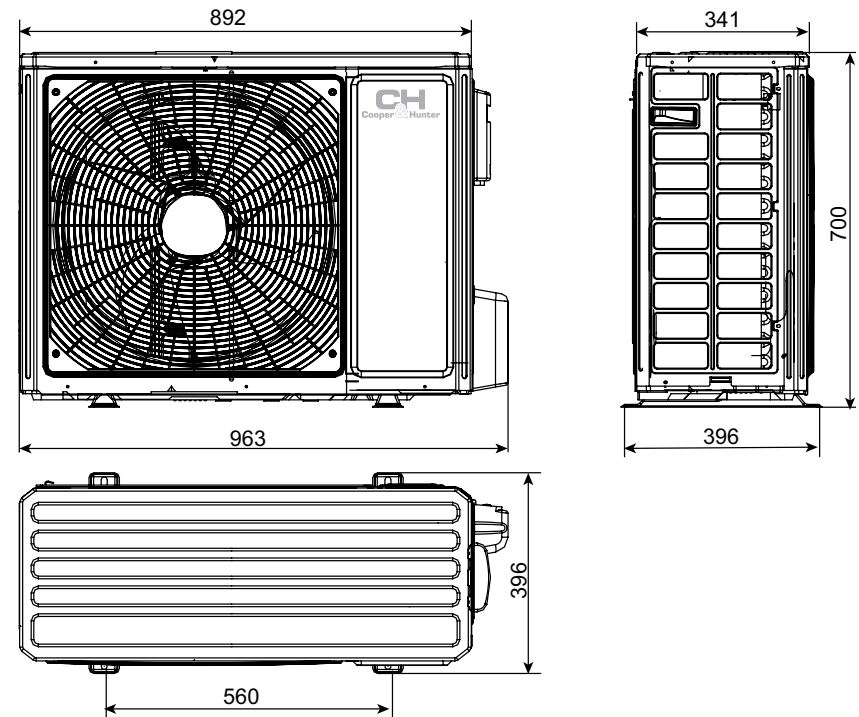
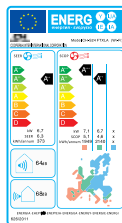
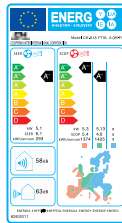

			CH-S09FTXLA	CH-S12FTXLA	CH-S18FTXLA	CH-S24FTXLA
Capacity	Cold	kW	2.60 (0.44-3.26)	3.50 (0.60-4.05)	5.13 (1.05-6.50)	6.70 (1.50-7.00)
	Warm	kW	2.80 (0.44-4.20)	3.67 (0.60-5.25)	5.275 (1.00-7.00)	7.25 (1.20-7.80)
Electric power supply			- 220-240V/50Hz			
Rated input	Cold	kW	0.59 (0.20-1.35)	0.80 (0.22-1.45)	1.28 (0.36-2.50)	1.56 (0.35-2.50)
	Warm	kW	0.61 (0.20-1.45)	0.79 (0.22-1.55)	1.16 (0.35-2.60)	1.73 (0.35-2.70)
Seasonal system performance factor	SEER (cooling)	kW / kW	6.1 (A++)	6.1 (A++)	6.1 (A++)	6.3 (A++)
	SCOP (heating)	kW / kW	5.1 (A+++)	5.1 (A+++)	5.4 (A+++)	5.1 (A+++)
Air productive capacity		m ³ /h	330/430/490/560	330/460/540/660	520/610/720/800	800/900/1000/1150
Sound-pressure level	indoor unit	dB (A)	22/25/34/39	22/27/36/42	27/32/38/46	29/32/40/48
	outdoor unit	dB (A)	50	52	54	55
Type of refrigerant coolant			R410A			
Weight	indoor unit	kg	9	10	13.5	17
	outdoor unit	kg	28	29	45	53
Compressor type			Rotor			
Drainage		l/h	0.8	1.4	1.8	2.1
Temperature range	cooling	°C	-15 ... +48	-15 ... +48	-15 ... +48	-15 ... +48
	heating	°C	-25 ... +24	-25 ... +24	-25 ... +24	-25 ... +24
Weight of refrigerant coolant		kg	0.7	0.85	1.3	1.9
Liquid pipeline diameter		mm/inch	6.38/1/4"	6.38/1/4"	6.38/1/4"	6.38/1/4"
Gas pipeline diameter		mm/inch	9.53/3/8"	9.53/3/8"	12.7/1/2"	15.88/5/8"
Maximum pipeline level difference		m	10	10	10	10
Pipeline maximum length		m	15	20	25	25
Distance between the bolts of the outdoor unit fastening		mm	510	510	560	560

* SEER – Seasonal Energy Efficient Rating in the cooling mode. ** SCOP – seasonal system capacity ratio in the heating mode.

NORDIC EVO II WI FI SERIES

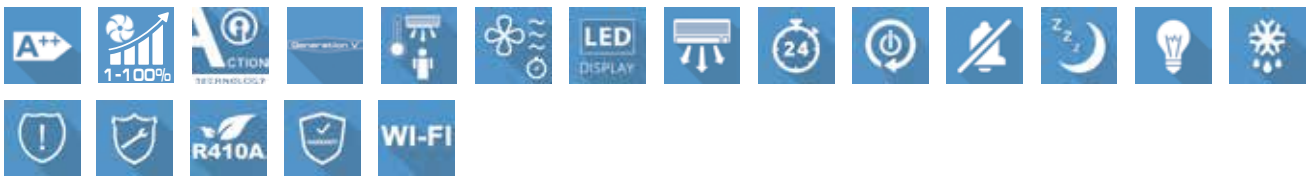

- Bigger structure for better performance and higher efficiency;
- Elegant LED display, hidden when the unit is off;
- Controlled by step-less regulation technology, the fan speed be adjust 1% to 100% between the highest and lowest speed;
- Operating temperature range: cooling from +18°C to +48°C, heating from -23°C to +24°C.



Model		CH-S09FTXN-E2wf	CH-S12FTXN-E2wf	CH-S18FTXN-E2wf	CH-S24FTXN-E2wf
Capacity	Cold kW	2.50 (0.78-2.90)	3.40 (1.30-3.90)	5.13 (1.00-6.70)	6.45 (1.40-7.00)
	Warm kW	2.80 (0.73- 3.30)	3.60 (0.80-4.20)	5.27 (1.10-6.80)	6.60 (1.50-7.90)
Power intake	Cold kW	0.58 (0.075-1.43)	0.79 (0.09-1.56)	1.19 (0.32-2.46)	1.50 (0.38-2.80)
	Warm kW	0.65 (0.135-1.55)	0.80 (0.14-1.65)	1.138 (0.35-2.30)	1.425 (0.40-2.50)

INDOOR UNIT

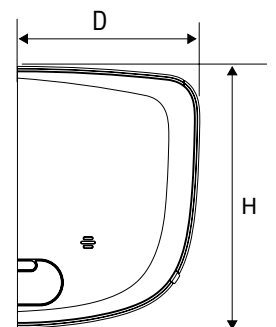
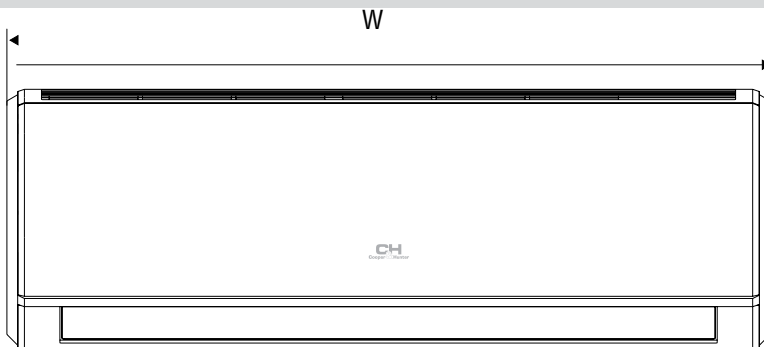

Model	W (mm)	H (mm)	D (mm)
CH-S09FTXN-E2wf	792	279	195
CH-S12FTXN-E2wf	792	279	195
CH-S18FTXN-E2wf	972	302	224
CH-S24FTXN-E2wf	1081	327	248

OUTDOOR UNIT

CH-S09FTXN-E2wf
CH-S12FTXN-E2wf

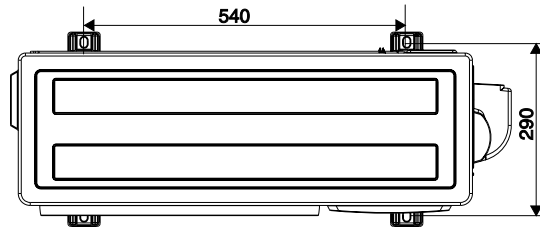
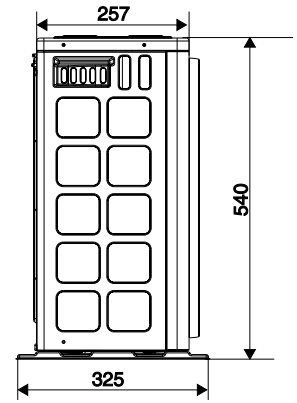
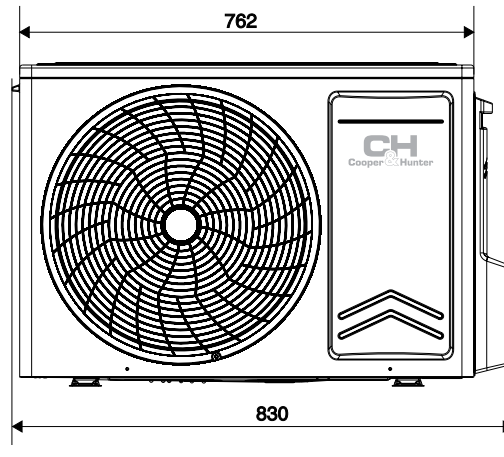
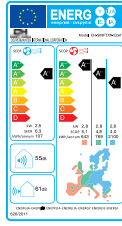

CH-S18FTXN-E2wf
CH-S24FTXN-E2wf

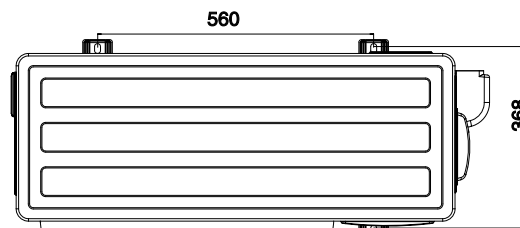
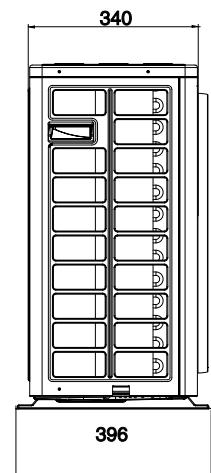
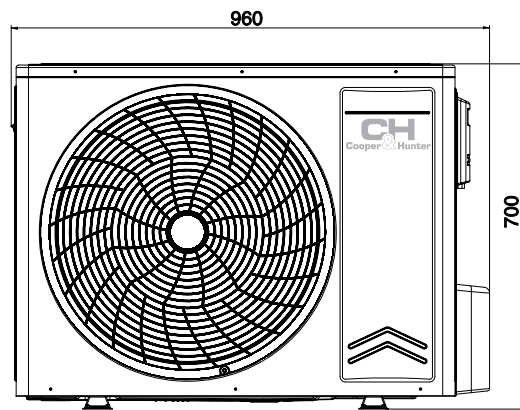
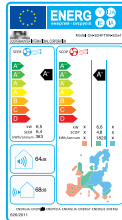
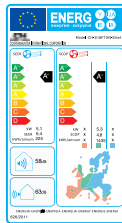

Model			CH-S09FTXN-E2wf	CH-S12FTXN-E2wf	CH-S18FTXN-E2wf	CH-S24FTXN-E2wf
Capacity	Cold	kW	2.50 (0.78-2.90)	3.40 (1.30-3.90)	5.13 (1.00-6.70)	6.45 (1.40-7.00)
	Warm	kW	2.80 (0.73-3.30)	3.60 (0.80-4.20)	5.27 (1.10-6.80)	6.60 (1.50-7.90)
Electric power supply			- 220-240V/50Hz/1Ph			
Rated input	Cold	kW	0.58 (0.075-1.43)	0.79 (0.09-1.56)	1.19 (0.32-2.46)	1.50 (0.38-2.80)
	Warm	kW	0.65 (0.135-1.55)	0.80 (0.14-1.65)	1.138 (0.35-2.30)	1.425 (0.40-2.50)
Energy performance	EER (Cold)/COP (Warm)	kW/kW	4.32/4.51	4.32/4.51	4.32/4.63	4.30/4.63
SEER*/SCOP** (energy performance class)			6.3 (A++)/4.8 (A++)		6.4 (A++)/4.8 (A++)	
Air productive capacity		m³/h	150/230/440/520	180/250/470/550	520/610/720/850	850/950/1050/1150
Sound-pressure level	indoor unit (min/ave/max)/ outdoor unit	dB (A)	19/24/36/40 52	20/25/37/41 53	28/39/42/46 56	28/42/45/48 60
	Type of refrigerant coolant	oz	R410A			
Weight	indoor unit/outdoor unit	kg	9/29	9/30	14/43	16.5/43.5
Compressor type			rotor			
Drainage		l/h	0.80	1.40	1.80	2.00
Operational temperature range cooling		°C	+18/+48			
Operational temperature range heating		°C	-23/+24			
Weight of refrigerant coolant		kg	0.70	0.90	1.25	1.45
Liquid pipeline diameter		mm/inch	6.38/1/4"	6.38/1/4"	6.38/1/4"	6.38/1/4"
Gas pipeline diameter		mm/inch	9.53/3/8"	9.53/3/8"	12.7/1/2"	16.7/5/8"
Maximum pipeline level difference		m	10	10	10	10
Pipeline maximum length		m	20	20	25	25
Distance between the bolts of the outdoor unit fastening		mm	540		560	

* SEER – Seasonal Energy Efficient Rating in the cooling mode. ** SCOP – seasonal system capacity ratio in the heating mode.

SIGMA SERIES

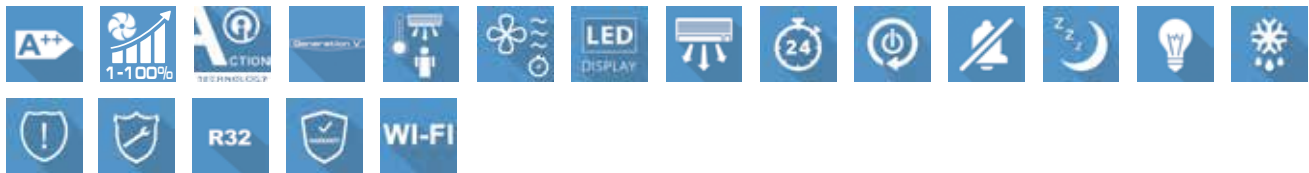

- Effective operation at temperature range;
- Cooling from +18 to +52, heating from -15 to +24;
- CH Smart-Ion Filter;
- LED display;
- I Feel function;
- Defends your home from frizzing: “+8 degrees” function. The air conditioner will support the temperature of 8C preventing the frizzing of the room and consuming the minimum of electric power.



Model		CH-S09FTXC	CH-S12FTXC	CH-S18FTXC	CH-S24FTXC
Capacity	Cold kW	2.50 (0.48-2.90)	3.40 (0.60-3.90)	5.27 (1.00-6.70)	6.45 (1.40-7.00)
	Warm kW	2.80 (0.73- 3.30)	3.60 (0.80-4.20)	5.50 (1.10-6.80)	6.60 (1.50-7.90)
Power intake	Cold kW	0.57 (0.13-1.43)	0.77 (0.09-1.56)	1.19 (0.32-2.46)	1.47 (0.38-2.80)
	Warm kW	0.65 (0.17-1.55)	0.80 (0.14-1.65)	1.19(0.35-2.30)	1.42 (0.40-2.50)

INDOOR UNIT

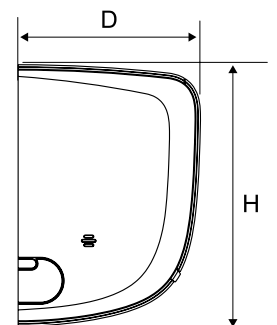
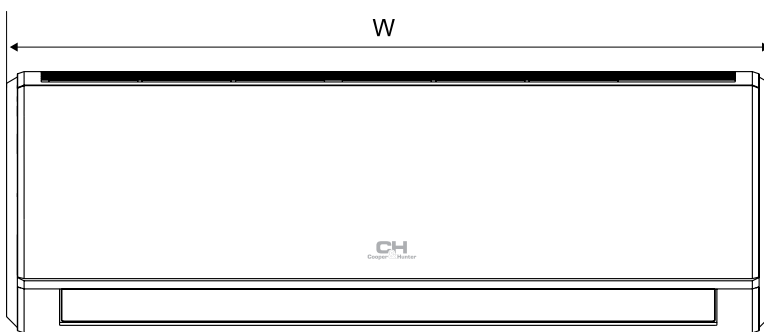

Model	W (mm)	H (mm)	D (mm)
CH-S09FTXC	792	279	195
CH-S12FTXC	792	279	195
CH-S18FTXC	972	302	224
CH-S24FTXC	1081	327	248

OUTDOOR UNIT

CH-S09FTXC
CH-S12FTXC

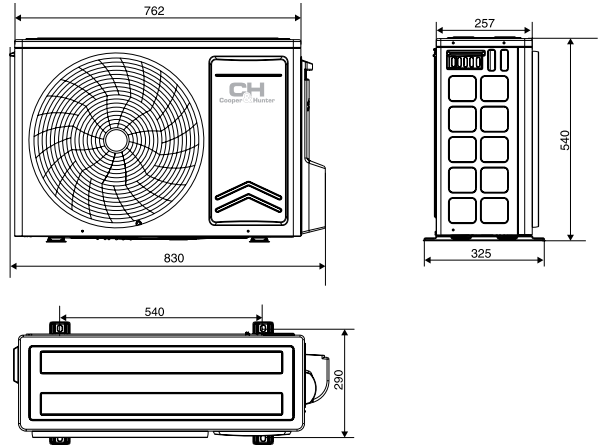
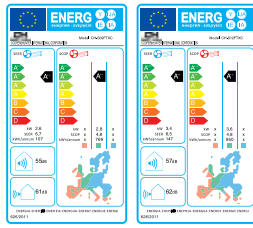

CH-S18FTXC

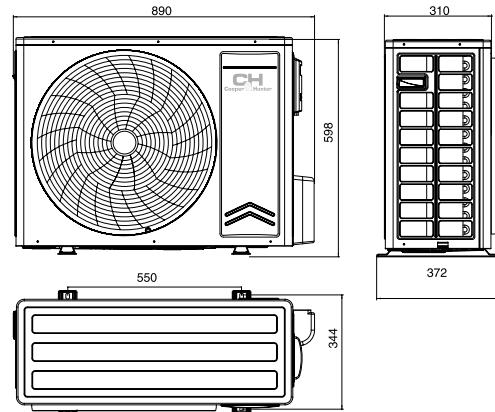
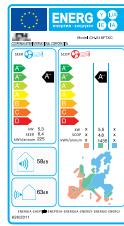

CH-S24FTXC

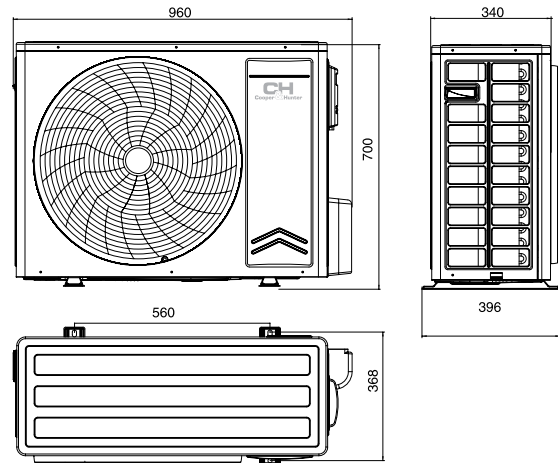
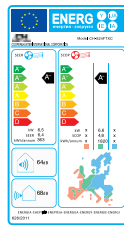

Model			CH-S09FTXC	CH-S12FTXC	CH-S18FTXC	CH-S24FTXC
Capacity	Cold	kW	2.50 (0.48-2.90)	3.40 (0.60-3.90)	5.27 (1.00-6.70)	6.45 (1.40-7.00)
	Warm	kW	2.80 (0.73-3.30)	3.60 (0.80-4.20)	5.50 (1.10-6.80)	6.60 (1.50-7.90)
Electric power supply			- 220-240V/50Hz/1Ph			
Rated input	Cold	kW	0.57 (0.13-1.43)	0.77 (0.09-1.56)	1.19 (0.32-2.46)	1.47 (0.38-2.80)
	Warm	kW	0.65 (0.17-1.55)	0.80 (0.14-1.65)	1.19 (0.35-2.30)	1.42 (0.40-2.50)
Energy performance	EER (Cold)/COP (Warm)	kW/kW	4.43/4.52	4.44/4.53	4.43/4.64	4.39/4.65
SEER*/SCOP** (energy performance class)			6.5 (A++)/4.8 (A++)		6.4 (A++)/4.8 (A++)	
Air productive capacity		m³/h	150/230/440/520	150/250/470/550	480/570/720/850	560/670/930/1090
Sound-pressure level	indoor unit (min/ave/max)	dB (A)	19/24/36/40	20/25/37/41	26/29/39/43	27/31/40/45
	outdoor unit		52	53	55	59
Type of refrigerant coolant		oz	R32			
Weight	indoor unit/outdoor unit	kg	9/29	9/30	13/40	16/43.5
Compressor type			rotor			
Drainage		l/h	0.80	1.40	1.80	2.40
Operational temperature range cooling		°C	+18/+52			
Operational temperature range heating		°C	-15/+24			
Weight of refrigerant coolant		kg	0.52	0.78	0.93	1.05
Liquid pipeline diameter		mm/inch	6.38/1/4"	6.38/1/4"	6.38/1/4"	6.38/1/4"
Gas pipeline diameter		mm/inch	9.53/3/8"	9.53/3/8"	12.7/1/2"	16.75/8"
Maximum pipeline level difference		m	10	10	10	10
Pipeline maximum length		m	20	20	25	25
Distance between the bolts of the outdoor unit fastening		mm	540		560	

* SEER – Seasonal Energy Efficient Rating in the cooling mode. ** SCOP – seasonal system capacity ratio in the heating mode.

SIGMA TROPIC SERIES



- Effective operation at temperature range cooling from +18 to +48, heating from -15 to +24
- Automatic Operation
- Auto Swing (Vertical Auto Swing)
- Dry Anti-Mildew Design
- CH Smart-Ion Filter
- LED display
- I Feel function



Model		CH-S12FTXC-T	CH-S18FTXC-T	CH-S24FTXC-T
Capacity	Cold kW	3.50 (0.55-4.00)	5.13 (1.00-6.70)	6.45 (1.40-7.00)
	Warm kW	3.65 (0.60-5.13)	5.27 (1.10-6.80)	6.60 (1.50-7.90)
Power intake	Cold kW	1.09 (0.18-1.56)	1.58 (0.32-2.46)	2.00 (0.38-2.80)
	Warm kW	1.03 (0.22-1.65)	1.50 (0.35-2.30)	1.88 (0.40-2.50)

INDOOR UNIT

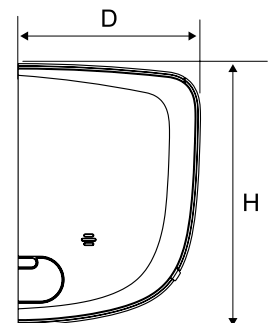
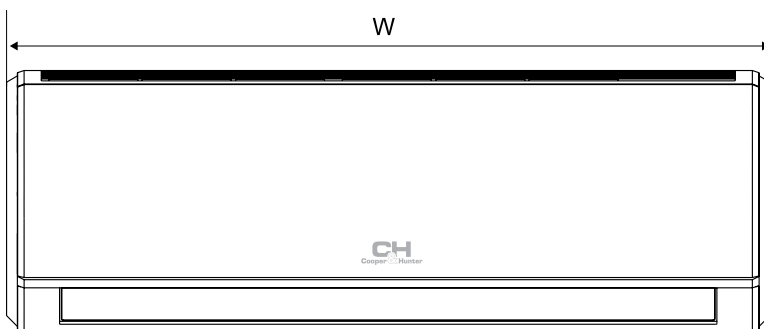

Model	W (mm)	H (mm)	D (mm)
CH-S12FTXC-T	850	291	203
CH-S18FTXC-T	972	302	224
CH-S24FTXC-T	1081	327	248

OUTDOOR UNIT

CH-S12FTXC-T

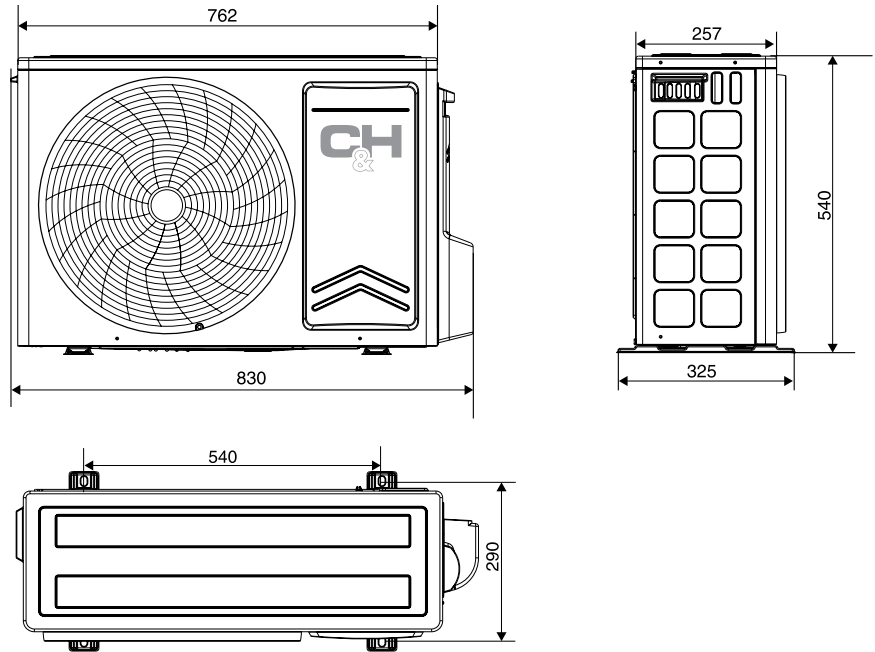

CH-S18FTXC-T
CH-S24FTXC-T

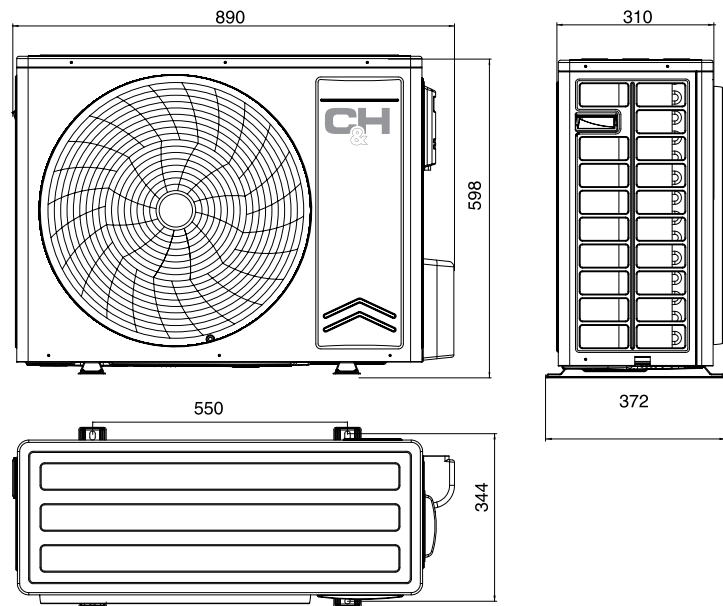

Model			CH-S12FTXC-T	CH-S18FTXC-T	CH-S24FTXC-T
Capacity	Cold	kW	3.50 (0.55-4.00)	5.13 (1.00-6.70)	6.45 (1.40-7.00)
	Warm	kW	3.65 (0.60-5.13)	5.27 (1.10-6.80)	6.60 (1.50-7.90)
Electric power supply			- 220-240V/50Hz/1Ph		
Rated input	Cold	kW	1.09 (0.18-1.56)	1.58 (0.32-2.46)	2.00 (0.38-2.80)
	Warm	kW	1.03 (0.22-1.65)	1.50 (0.35-2.30)	1.88 (0.40-2.50)
Energy performance	EER (Cold)/COP (Warm)	kW/kW	3.23/3.56	3.25/3.51	3.25/3.51
Air productive capacity			330/460/540/660	520/610/720/850	850/950/1050/1150
Sound-pressure level	indoor unit (min/ave/max)	dB (A)	27/33/38/42	28/39/42/46	28/42/45/48
	outdoor unit		53	55	58
Type of refrigerant coolant		oz	R410A		
Weight	indoor unit/outdoor unit	kg	10.5/30	14/40	16.5/42
Compressor type			rotor		
Drainage			1.40	1.80	2.40
Operational temperature range cooling	°C		+18/+48	+18/+48	+18/+48
Operational temperature range heating	°C		-15/+24	-15/+24	-15/+24
Weight of refrigerant coolant	kg		0.90	1.25	1.45
Liquid pipeline diameter	mm/inch		6.38/1/4"	6.38/1/4"	6.38/1/4"
Gas pipeline diameter	mm/inch		9.53/3/8"	12.7/1/2"	16.7/5/8"
Maximum pipeline level difference	m		10	10	10
Pipeline maximum length	m		20	25	25
Distance between the bolts of the outdoor unit fastening	mm		540	550	550

* SEER – Seasonal Energy Efficient Rating in the cooling mode. ** SCOP – seasonal system capacity ratio in the heating mode.

VERITAS NG SERIES



INVERTER

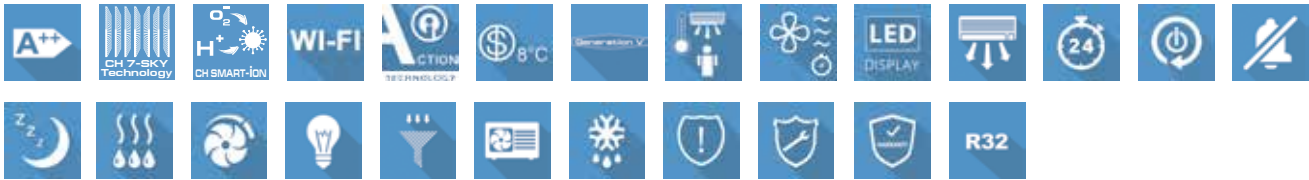

- Operating temperature range: cooling from -15°C to +48°C, heating from -15°C to +24°C
- Defends your home from frizzing: “+8 degrees” function. The air conditioner will support the temperature of 8°C preventing the frizzing of the room and consuming the minimum of electric power.
- The premium remote control with a new ergonomic body frame and a night lighting



Model		CH-S09FTXQ-NG	CH-S12FTXQ-NG	CH-S18FTXQ-NG	CH-S24FTXLQ-NG
Capacity	kW Cold	2.60 (0.44-3.00)	3.50 (0.60-3.60)	5.0 (0.65-5.20)	6.45 (2.00-8.20)
	kW Warm	2.80 (0.60-3.20)	3.60 (0.60-3.80)	5.30 (0.70-5.28)	6.45 (2.00-8.50)
Power intake	kW Cold	0.718 (0.12-1.30)	0.972 (0.12-1.40)	1.43 (0.15-1.86)	1.79 (0.40-3.00)
	kW Warm	0.733 (0.12-1.40)	0.942 (0.12-1.50)	1.38 (0.16-1.68)	1.68 (0.45-3.10)

INDOOR UNIT

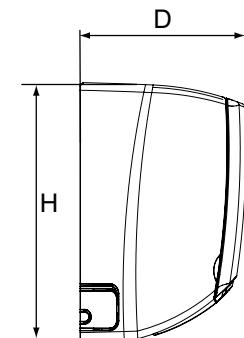
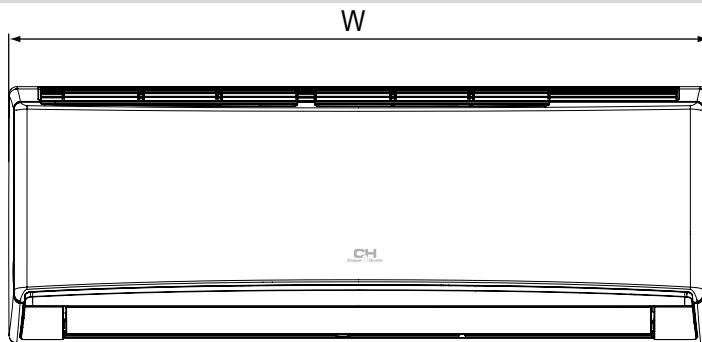

Model	W (mm)	H (mm)	D (mm)
CH-S09FTXQ-NG	790	275	200
CH-S12FTXQ-NG	790	275	200
CH-S18FTXQ-NG	970	300	225
CH-S24FTXLQ-NG	1078	325	246

OUTDOOR UNIT

CH-S09FTXQ-NG

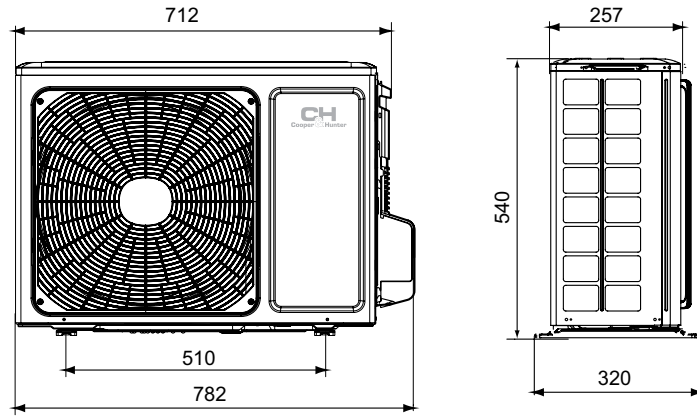
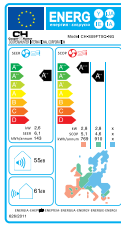

CH-S12FTXQ-NG
CH-S18FTXQ-NG

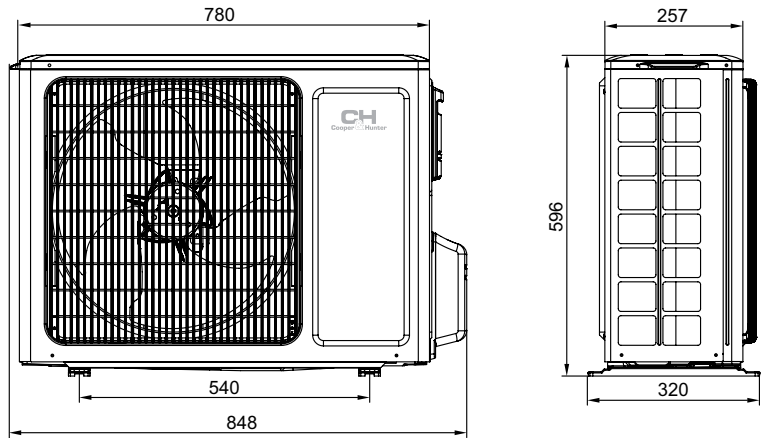
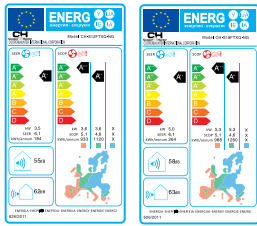

CH-S24FTXLQ-NG

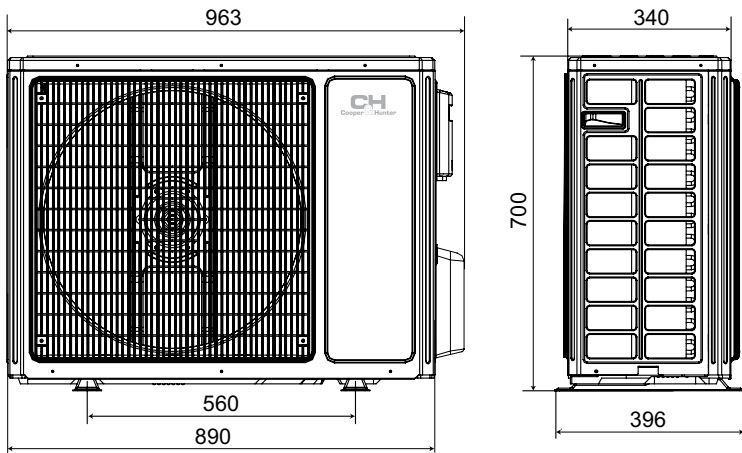
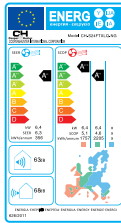

Model			CH-S09FTXQ-NG	CH-S12FTXQ-NG	CH-S18FTXQ-NG	CH-S24FTXLQ-NG
Capacity	Cold/	kW	2.60 (0.44-3.00)	3.50 (0.60-3.60)	5.0 (0.65-5.20)	6.45 (2.00-8.20)
	Warm	kW	2.80 (0.60-3.20)	3.60 (0.60-3.80)	5.30 (0.70-5.28)	6.45 (2.00-8.50)
Electric power supply			- 220-240V/50Hz/1Ph			
Rated input	Cold	kW	0.72 (0.16-1.40)	0.97 (0.12-1.40)	1.39 (0.15-1.70)	1.79 (0.40-3.00)
	Warm	kW	0.71 (0.20-1.50)	0.92 (0.12-1.50)	1.34 (0.16-1.6.0)	1.68 (0.45-3.10)
Energy performance	EER (Cold)/COP (Warm)	kW/kW	3.62/3.93	3.60/3.93	3.50/3.95	3.60/3.84
SEER*/SCOP** (energy performance class)			6.1 (A++)/4.6 (A++)	6.1 (A++)/4.6 (A++)	6.1 (A++)/4.6 (A++)	6.3 (A++)/5.1 (A++)
Air productive capacity		m³/h	330/430/490/560	290/410/480/560	520/610/720/850	850/950/1050/1250
Sound-pressure level	indoor unit (min/ave/max)/	dB (A)	23/26/30/36	24/28/32/37	28/33/39/45	30/34/39/44
	outdoor unit					
Type of refrigerant coolant		oz	R 32			
Weight	indoor unit/outdoor unit	kg	9/29.5	9/31	13.5/34	16.5/52.5
Compressor type			rotor			
Drainage		l/h	0.8	1.4	1.8	2.0
Operational temperature range cooling		°C	-15/+48	-15/+48	-15/+48	-15/+48
Operational temperature range heating		°C	-15/+24	-15/+24	-15/+24	-25/+24
Weight of refrigerant coolant		kg	0.6	0.59	0.77	1.70
Liquid pipeline diameter		mm/inch	6.38/1/4"	6.38/1/4"	6.38/1/4"	6.38/1/4"
Gas pipeline diameter		mm/inch	9.53/3/8"	9.53/3/8"	9.53/3/8"	15.88/5/8"
Maximum pipeline level difference		m	10	10	10	10
Pipeline maximum length		m	19	20	20	25
Distance between the bolts of the outdoor unit fastening		mm	510	540	540	560

* SEER – Seasonal Energy Efficient Rating in the cooling mode. ** SCOP – seasonal system capacity ratio in the heating mode.

VERITAS SERIES



INVERTER



- Operating temperature range: cooling from -15°C to +48°C, heating from -15°C to +24°C
- Defends your home from frizzing: “+8 degrees” function. The air conditioner will support the temperature of 8°C preventing the frizzing of the room and consuming the minimum of electric power.
- The premium remote control with a new ergonomic body frame and a night lighting



Model		CH-S07FTXQ	CH-S09FTXQ	CH-S12FTXQ	CH-S18FTXQ	CH-S24FTXLQ
Capacity	kW Cold	2.20 (0.37-2.53)	2.60 (0.44-3.00)	3.50 (0.60-3.60)	5.0 (0.65-5.20)	6.70 (2.00-8.20)
	kW Warm	2.30 (0.51-2.60)	2.80 (0.60-3.20)	3.60 (0.60-3.80)	5.30 (0.70-5.28)	7.25 (2.00-8.50)
Power intake	kW Cold	0.608 (0.10-0.95)	0.718 (0.12-1.30)	0.972 (0.12-1.40)	1.43 (0.15-1.86)	1.56 (0.35-2.50)
	kW Warm	0.602 (0.10-0.91)	0.733 (0.12-1.40)	0.942 (0.12-1.50)	1.38 (0.16-1.68)	1.73 (0.35-2.70)

INDOOR UNIT

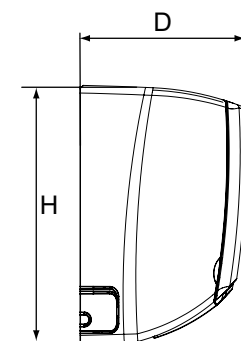
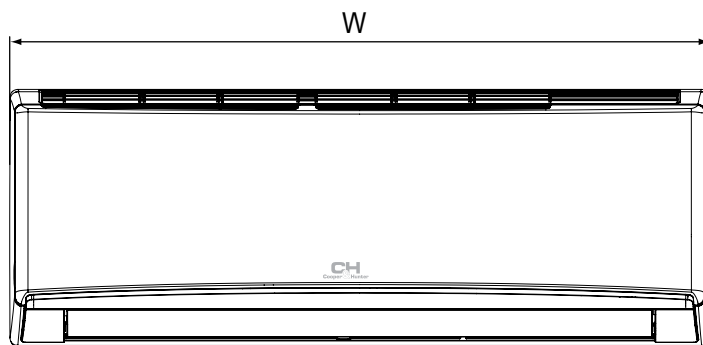

Model	W (mm)	H (mm)	D (mm)
CH-S07FTXQ	713	270	195
CH-S09FTXQ	790	275	200
CH-S12FTXQ	790	275	200
CH-S18FTXQ	970	300	224
CH-S24 FTXLQ	1078	325	246

OUTDOOR UNIT

CH-S07FTXQ

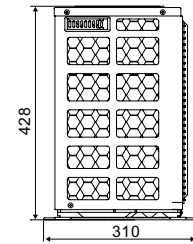
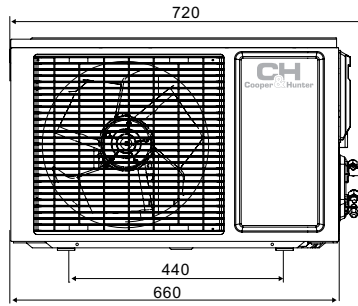
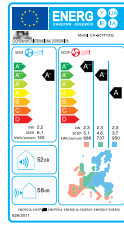

CH-S09FTXQ

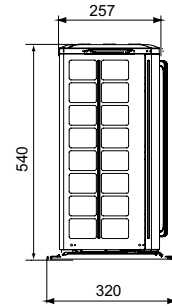
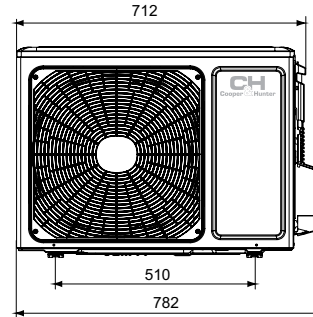
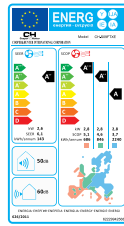

CH-S12FTXQ
CH-S18FTXQ

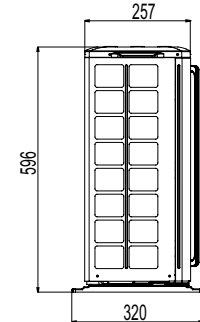
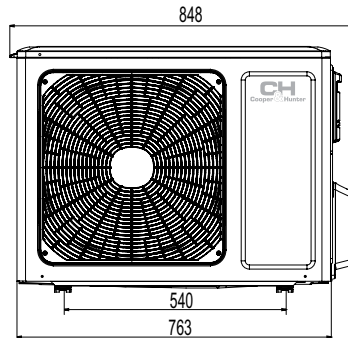
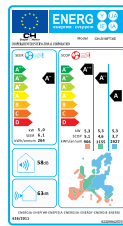
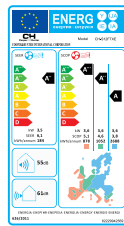

CH-S24FTXLQ

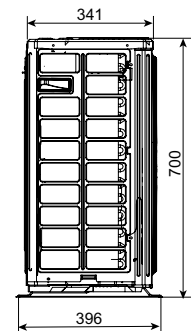
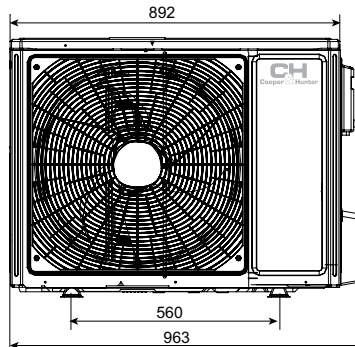

Model			CH-S07FTXQ	CH-S09FTXQ	CH-S12FTXQ	CH-S18FTXQ	CH-S24FTXLQ
Capacity	Cold	kW	2.20 (0.37-2.53)	2.60 (0.44-3.00)	3.50 (0.60-3.60)	5.0 (0.65-5.20)	6.70 (2.00-8.20)
	Warm	kW	2.30 (0.51-2.60)	2.80 (0.60-3.20)	3.60 (0.60-3.80)	5.30 (0.70-5.28)	7.25 (2.00-8.50)
Electric power supply			- 220-240V/50Hz				
Rated input	Cold	kW	0.608 (0.10-0.95)	0.718 (0.12-1.30)	0.972 (0.12-1.40)	1.43 (0.15-1.86)	1.56 (0.35-2.50)
	Warm	kW	0.602 (0.10-0.91)	0.733 (0.12-1.40)	0.942 (0.12-1.50)	1.38 (0.16-1.68)	1.73 (0.35-2.70)
Energy performance	EER (Cold)/COP (Warm)	kW/kW	3.61/3.83	3.62/3.82	3.60/3.82	3.50/3.84	3.60/3.84
SEER*/SCOP** (energy performance class)			6.1 (A++)/4.6 (A++)	6.1 (A++)/4.6 (A++)	6.1 (A++)/4.6 (A++)	6.1 (A++)/4.6 (A++)	6.3 (A++)/5.1 (A++)
Air productive capacity		m ³ /h	300/390/420/500	210/320/370/480	290/410/480/560	520/610/720/850	800/900/1000/1150
Sound-pressure level	indoor unit (min/ave/max)/	dB (A)	22/25/27/29	23/26/35/38	24/28/37/40	28/33/39/44	29/32/40/48
	outdoor unit						
Type of refrigerant coolant		oz	R410A				
Weight	indoor unit/outdoor unit	kg	8.5/21.5	9/26.5	9/31	13.5/33.5	17/53
Compressor type			rotor				
Drainage		l/h	0.8	0.8	1.4	1.8	2.1
Operational temperature range cooling		°C	-15/+48				
Operational temperature range heating		°C	-15/+24				
Weight of refrigerant coolant		kg	0.55	0.7	0.85	1.2	1.9
Liquid pipeline diameter		mm/inch	6.38/1/4"	6.38/1/4"	6.38/1/4"	6.38/1/4"	6.38/1/4"
Gas pipeline diameter		mm/inch	9.53/3/8"	9.53/3/8"	9.53/3/8"	9.53/3/8"	15.88/5/8"
Maximum pipeline level difference		m	10	10	10	10	10
Pipeline maximum length		m	15	15	20	20	25
Distance between the bolts of the outdoor unit fastening		mm	440	510	540	540	560

* SEER – Seasonal Energy Efficient Rating in the cooling mode. ** SCOP – seasonal system capacity ratio in the heating mode.

ALPHA NG SERIES



INVERTER

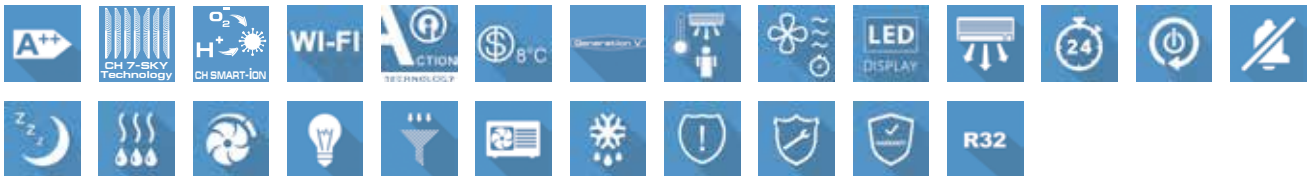

- Operating temperature range: cooling from -15°C to +48°C, heating from -15°C to +24°C;
- Defends your home from frizzing: “+8 degrees” function. The air conditioner will support the temperature of 8°C preventing the frizzing of the room and consuming the minimum of electric power;
- The premium remote control with a new ergonomic body frame and a night lighting.



Model		CH-S09FTXE-NG	CH-S12FTXE-NG	CH-S18FTXE-NG	CH-S24FTXLE-NG
Capacity	Cold Kw	2.60 (0.44-3.00)	3.50 (0.60-3.60)	5.0 (0.65-5.20)	6.45 (2.00-8.20)
	Warm Kw	2.80 (0.60-3.20)	3.60 (0.60-3.80)	5.30 (0.70-5.28)	6.45 (2.00-8.50)
Power intake	Cold Kw	0.718 (0.12-1.30)	0.972 (0.12-1.40)	1.43 (0.15-1.86)	1.875 (0.40-3.70)
	Warm Kw	0.733 (0.12-1.40)	0.942 (0.12-1.50)	1.38 (0.16-1.68)	1.945 (0.45-3.80)

INDOOR UNIT

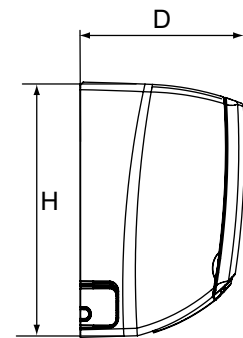
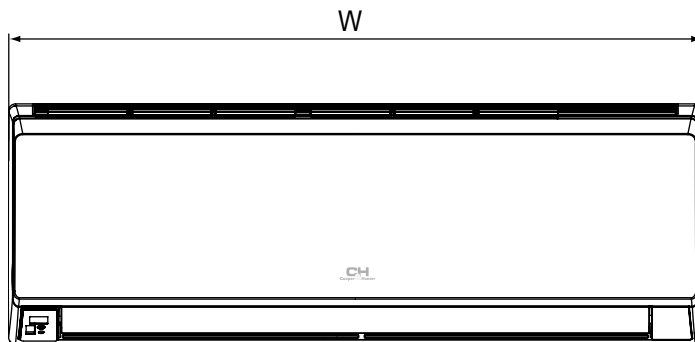

Model	W (mm)	H (mm)	D (mm)
CH-S09FTXE-NG	790	275	200
CH-S12FTXE-NG	790	275	200
CH-S18FTXE-NG	970	300	225
CH-S24FTXLE-NG	1078	325	246

OUTDOOR UNIT

CH-S09FTXE-NG

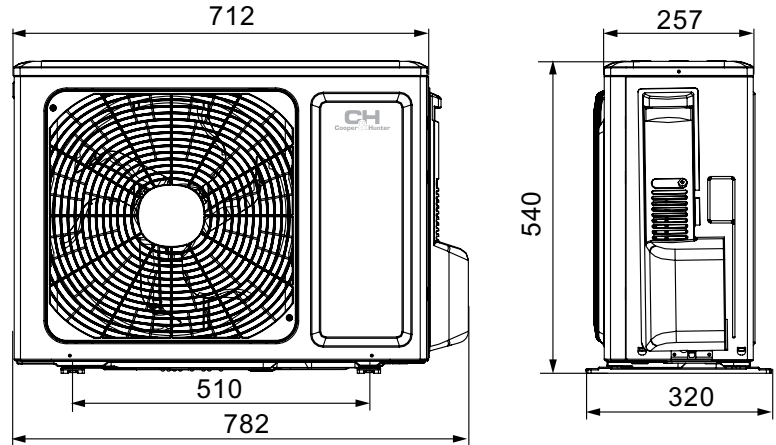
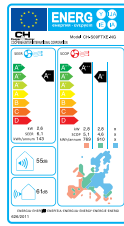

CH-S12FTXE-NG
CH-S18FTXE-NG

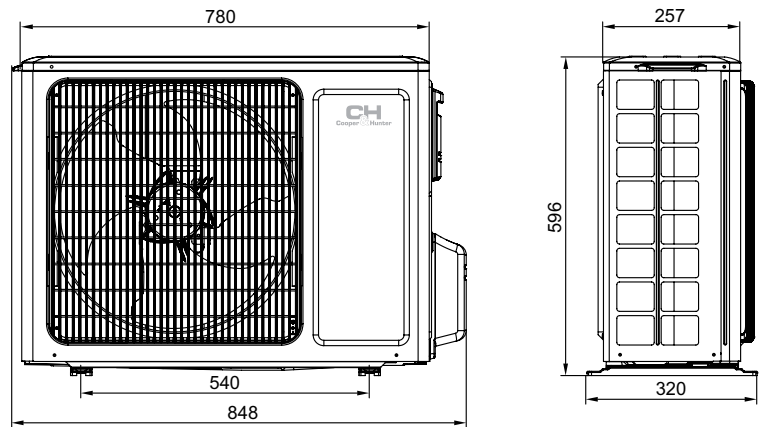
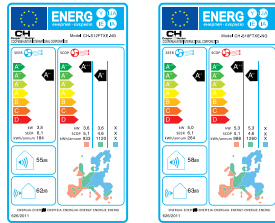

CH-S24FTXLE-NG

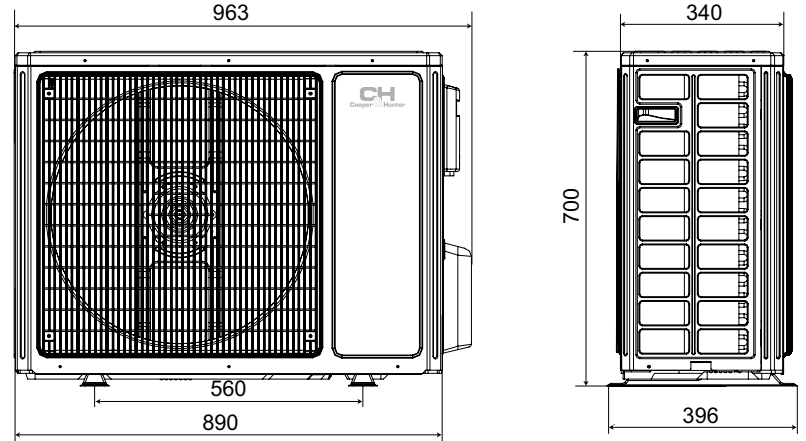
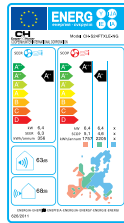

Model			CH-S09FTXE-NG	CH-S12FTXE-NG	CH-S18FTXE-NG	CH-S24FTXLE-NG
Capacity	Cold/	kW	2.60 (0.44-3.00)	3.50 (0.60-3.60)	5.0 (0.65-5.20)	6.45 (2.00-8.20)
	Warm	kW	2.80 (0.60-3.20)	3.60 (0.60-3.80)	5.30 (0.70-5.28)	6.45 (2.00-8.50)
Electric power supply			- 220-240V/50Hz/1Ph			
Rated input	Cold	kW	0.72 (0.16-1.40)	0.97 (0.12-1.40)	1.39 (0.15-1.70)	1.875 (0.40-3.70)
	Warm	kW	0.71 (0.20-1.50)	0.92 (0.12-1.50)	1.34 (0.16-1.6.0)	1.945 (0.45-3.80)
Energy performance	EER (Cold)/COP (Warm)	kW/kW	3.62/3.93		3.50/3.95	
SEER*/SCOP** (energy performance class)			6.1 (A++)/4.6 (A++)		6.1 (A++)/4.6 (A++)	
Air productive capacity		m ³ /h	330/430/490/560		520/610/720/850	
Sound-pressure level	indoor unit (min/ave/max)/	dB (A)	23/26/30/36		28/33/39/45	
	outdoor unit		49		58	
Type of refrigerant coolant		oz	R 32			
Weight	indoor unit/outdoor unit	kg	9/29.5	9/31	13.5/34	16.5/52.5
Compressor type			rotor			
Drainage		l/h	0.8	1.4	1.8	2.0
Operational temperature range cooling		°C	-15/+48			
Operational temperature range heating		°C	-15/+24			
Weight of refrigerant coolant		kg	0.6			
Liquid pipeline diameter		mm/inch	6.38/1/4"			
Gas pipeline diameter		mm/inch	9.53/3/8"			
Maximum pipeline level difference		m	10			
Pipeline maximum length		m	19			
Distance between the bolts of the outdoor unit fastening		mm	510		540	

* SEER – Seasonal Energy Efficient Rating in the cooling mode. ** SCOP – seasonal system capacity ratio in the heating mode.

ALPHA SERIES



INVERTER



- Operating temperature range: cooling from -15°C to +48°C, heating from -15°C to +24°C;
- Defends your home from frizzing: “+8 degrees” function. The air conditioner will support the temperature of 8°C preventing the frizzing of the room and consuming the minimum of electric power;
- The premium remote control with a new ergonomic body frame and a night lighting.



Model		CH-S07FTXE	CH-S09FTXE (Wi Fi)	CH-S12FTXE (Wi Fi)	CH-S18FTXE (Wi Fi)	CH-S24FTXLE (Wi Fi)
Capacity	Cold Kw	2.20 (0.37-2.53)	2.60 (0.44-3.00)	3.50 (0.60-3.60)	5.0 (0.65-5.20)	6.70 (2.00-8.20)
	Warm Kw	2.30 (0.51-2.60)	2.80 (0.60-3.20)	3.60 (0.60-3.80)	5.30 (0.70-5.28)	7.25 (2.00-8.50)
Power intake	Cold Kw	0.608 (0.10-0.95)	0.718 (0.12-1.30)	0.972 (0.12-1.40)	1.43 (0.15-1.86)	1.56 (0.35-2.50)
	Warm Kw	0.602 (0.10-.91)	0.733 (0.12-1.40)	0.942 (0.12-1.50)	1.38 (0.16-1.68)	1.73 (0.35-2.70)

INDOOR UNIT

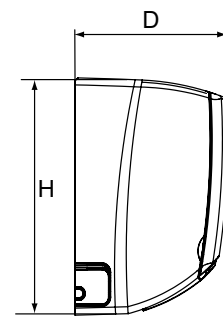
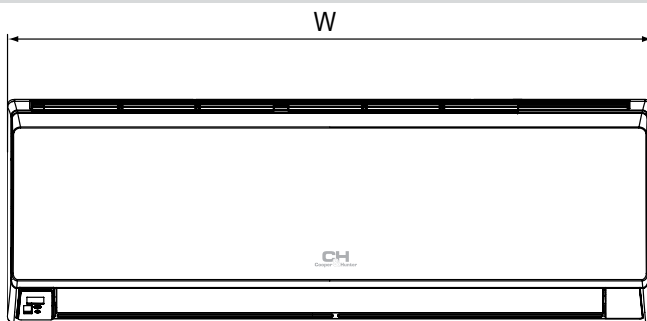

Model	W (mm)	H (mm)	D (mm)
CH-S07FTXE	713	270	195
CH-S09FTXE (Wi Fi)	790	275	200
CH-S12FTXE (Wi Fi)	790	275	200
CH-S18FTXE (Wi Fi)	970	300	224
CH-S24FTXLE (Wi Fi)	1078	325	246

OUTDOOR UNIT

CH-S07FTXE

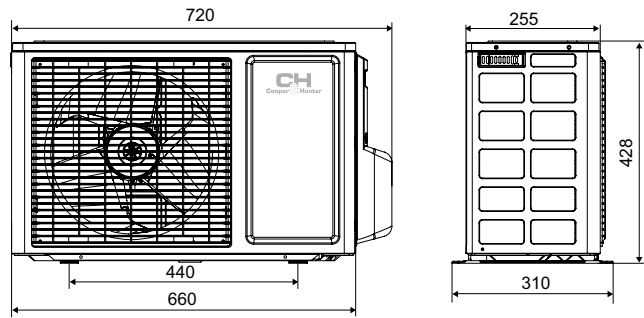

CH-S09FTXE (Wi Fi)

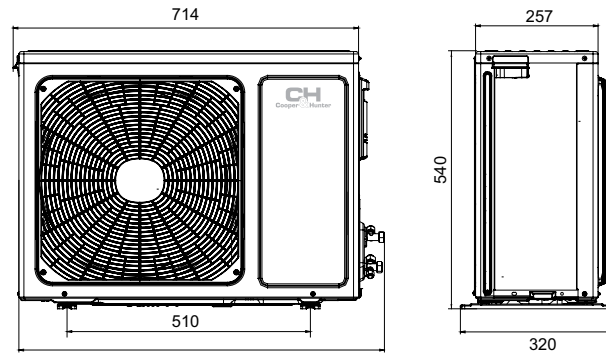
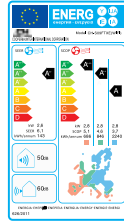

CH-S12FTXE (Wi Fi)
CH-S18FTXE (Wi Fi)

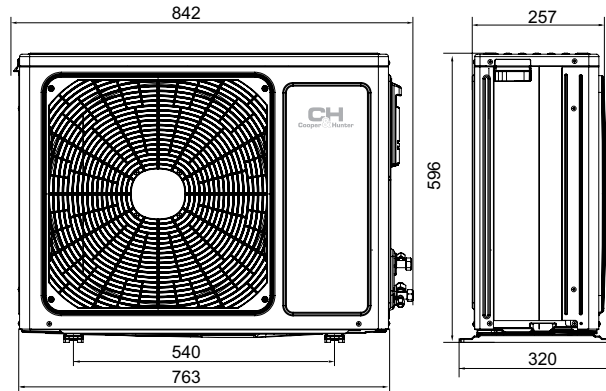
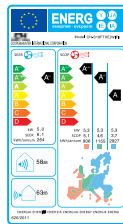
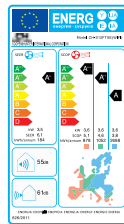

CH-S24FTXLE (Wi Fi)

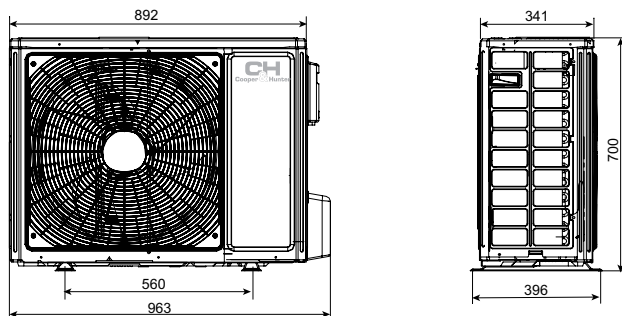
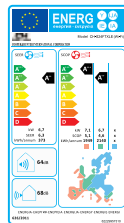

Model			CH-S07FTXE	CH-S09FTXE (Wi Fi)	CH-S12FTXE (Wi Fi)	CH-S18FTXE (Wi Fi)	CH-S24FTXLE (Wi Fi)
Capacity	Cold/	kW	2.20 (0.37-2.53)	2.60 (0.44-3.00)	3.50 (0.60-3.60)	5.0 (0.65-5.20)	6.70 (2.00-8.20)
	Warm	kW	2.30 (0.51-2.60)	2.80 (0.60-3.20)	3.60 (0.60-3.80)	5.30 (0.70-5.28)	7.25 (2.00-8.50)
Electric power supply			- 220-240V/50Hz/1Ph				
Rated input	Cold	kW	0.608 (0.10-0.95)	0.718 (0.12-1.30)	0.972 (0.12-1.40)	1.43 (0.15-1.86)	1.56 (0.35-2.50)
	Warm	kW	0.602 (0.10-0.91)	0.733 (0.12-1.40)	0.942 (0.12-1.50)	1.38 (0.16-1.68)	1.73 (0.35-2.70)
Energy performance	EER (Cold)/COP (Warm)	kW/kW	3.61/3.83	3.62/3.82	3.60/3.82	3.50/3.84	6.3 (A++)
SEER*/SCOP** (energy performance class)			6.1 (A++)/4.6 (A++)	6.1 (A++)/4.6 (A++)	6.1 (A++)/4.6 (A++)	6.1 (A++)/4.6 (A++)	5.1 (A++)
Air productive capacity		m³/h	300/390/420/500	210/320/370/480	290/410/480/560	520/610/720/850	1150/1000/900/800
Sound-pressure level	indoor unit (min/ave/max)/	dB (A)	22/25/27/29	23/26/35/38	24/28/37/40	28/33/39/44	29/32/40/48
	outdoor unit						
Type of refrigerant coolant		oz	R410A				
Weight	indoor unit/outdoor unit	kg	8.5/21.5	9/26.5	9/31	13.5/33.5	17/53
Compressor type			Rotor				
Drainage		l/h	0.8	0.8	1.4	1.8	2.1
Operational temperature range cooling		°C	-15/+48				
Operational temperature range heating		°C	-15/+24				
Weight of refrigerant coolant		kg	0.55	0.7	0.85	1.2	1.9
Liquid pipeline diameter		mm/inch	6.38/1/4"	6.38/1/4"	6.38/1/4"	6.38/1/4"	6.38/1/4"
Gas pipeline diameter		mm/inch	9.53/3/8"	9.53/3/8"	9.53/3/8"	9.53/3/8"	15.88/5/8"
Maximum pipeline level difference		m	10	10	10	10	10
Pipeline maximum length		m	15	15	20	20	25
Distance between the bolts of the outdoor unit fastening		mm	440	510	540	540	560

* SEER – Seasonal Energy Efficient Rating in the cooling mode. ** SCOP – seasonal system capacity ratio in the heating mode.

WINNER SERIES



INVERTER



- Operates till -15°C in the heating and cooling modes;
- Operating temperature range: cooling from -15°C to +48°C, heating from -15°C to +24°C;
- Defends your home from frizzing: “+8 degrees” function.
The air conditioner will support the temperature of 8°C preventing the freezing of the room and consuming the minimum of electric power;
- Wide angle louvers;
- Precise temperature operation range within 0,5°C.



Model		CH-S07FTX5	CH-S09FTX5	CH-S12FTX5	CH-S18FTX5	CH-S24FTX5
Capacity	kW Cold	2.20 (0.37-2.53)	2.60 (0.44-3.00)	3.50 (0.60-3.60)	5.0 (0.65-5.20)	6.70 (2.00-8.20)
	kW Warm	2.30 (0.51-2.60)	2.80 (0.60-3.20)	3.60 (0.60-3.80)	5.30 (0.70-5.28)	7.25 (2.00-8.50)
Power intake	kW Cold	0.608 (0.10-0.95)	0.718 (0.12-1.30)	0.972 (0.12-1.40)	1.43 (0.15-1.86)	1.875 (0.40-3.70)
	kW Warm	0.602 (0.10-.91)	0.733 (0.12-1.40)	0.942 (0.12-1.50)	1.38 (0.16-1.68)	1.945 (0.45-3.80)

INDOOR UNIT

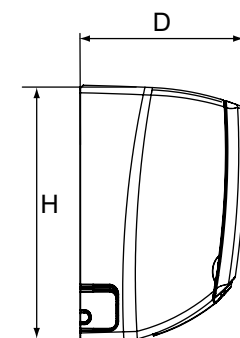
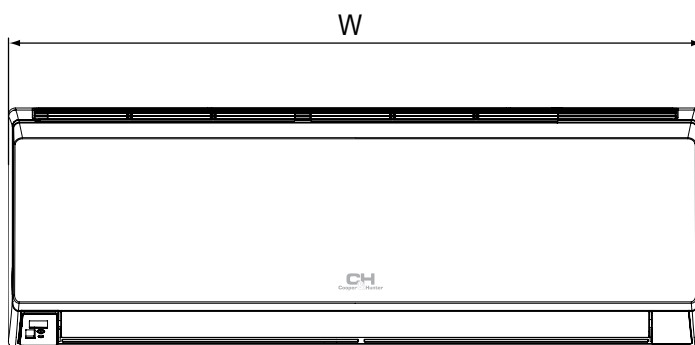

Model	W (mm)	H (mm)	D (mm)
CH-S07FTX5	790	275	200
CH-S09FTX5	790	275	200
CH-S12FTX5	790	275	200
CH-S18FTX5	970	300	224
CH-S24FTX5	1078	325	246

OUTDOOR UNIT

CH-S07FTX5

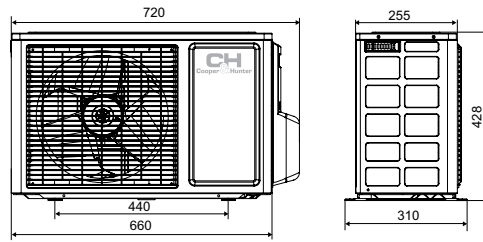
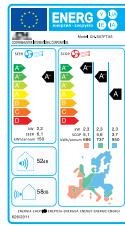

CH-S09FTX5

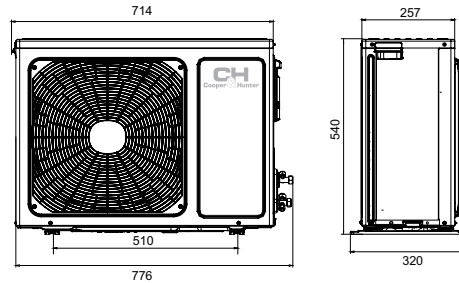
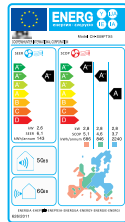

CH-S12FTX5

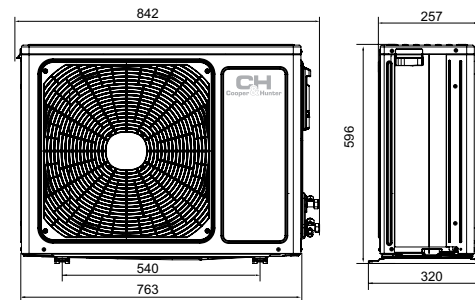
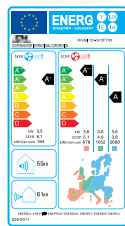

CH-S18FTX5

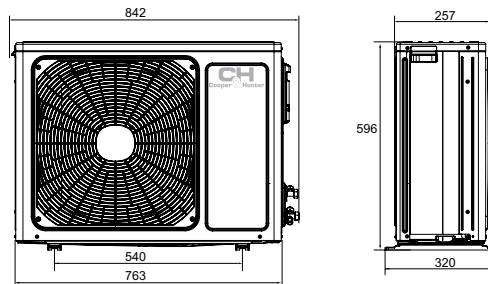
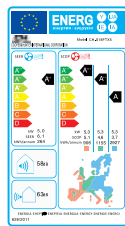

CH-S24FTX5

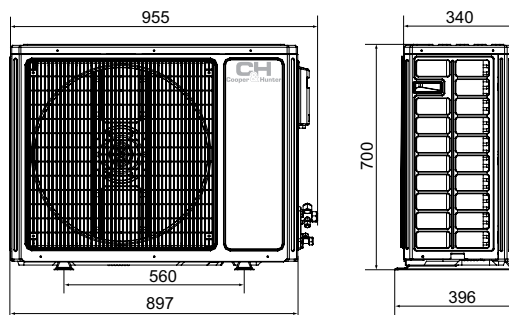
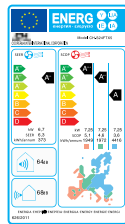

Model			CH-S07FTX5	CH-S09FTX5	CH-S12FTX5	CH-S18FTX5	CH-S24FTX5
Capacity	Cold	kW	2.20 (0.37-2.53)	2.60 (0.44-3.00)	3.50 (0.60-3.60)	5.0 (0.65-5.20)	6.70 (2.00-8.20)
	Warm	kW	2.30 (0.51-2.60)	2.80 (0.60-3.20)	3.60 (0.60-3.80)	5.30 (0.70-5.28)	7.25 (2.00-8.50)
Electric power supply							- 220-240V/50Hz
Rated input	Cold	kW	0.608 (0.10-0.95)	0.718 (0.12-1.30)	0.972 (0.12-1.40)	1.43 (0.15-1.86)	1.875 (0.40-3.70)
	Warm	kW	0.602 (0.10-0.91)	0.733 (0.12-1.40)	0.942 (0.12-1.50)	1.38 (0.16-1.68)	1.945 (0.45-3.80)
Energy performance	EER (Cold)/COP(Warm)	kW/kW	3.61/3.83	3.62/3.82	3.60/3.82	3.50/3.84	3.57/3.73
SEER*/SCOP** (energy performance class)			6.1 (A++)/4.6 (A++)	6.1 (A++)/4.6 (A++)	6.1 (A++)/4.6 (A++)	6.1 (A++)/4.6 (A++)	6.3 (A++)/4.6 (A++)
Air productive capacity		m³/h	300/390/420/500	210/320/ 370/480	290/410/480/560	520/610/720/850	850/950/1000/1150
Sound-pressure level	indoor unit (min/ave/max)/	dB (A)	22/25/27/29	23/26/35/38	24/28/37/40	28/33/39/44	30/33/40/45
	outdoor unit						
Type of refrigerant coolant			R410A				
Weight	indoor unit/outdoor unit	kg	8.5/21.5	9/26.5	9/31	13.5/33.5	17/53
Compressor type			rotor				
Drainage		l/h	0.8	0.8	1.4	1.8	2.0
Operational temperature range cooling		°C	-15/+48				
Operational temperature range heating		°C	-15/+24				
Weight of refrigerant coolant		kg	0.55	0.7	0.90	1.1	1.9
Liquid pipeline diameter		mm/inch	6.38/1/4"	6.38/1/4"	6.38/1/4"	6.38/1/4"	6.38/1/4"
Gas pipeline diameter		mm/inch	9.53/3/8"	9.53/3/8"	9.53/3/8"	9.53/3/8"	15.88/5/8"
Maximum pipeline level difference		m	10	10	10	10	10
Pipeline maximum length		m	15	15	20	20	25
Distance between the bolts of the outdoor unit fastening		mm	440	510	540	540	560

* SEER – Seasonal Energy Efficient Rating in the cooling mode. ** SCOP – seasonal system capacity ratio in the heating mode.

TERRA SERIES



INVERTER



- Wide operating temperature range: cooling from +10°C to +43°C, heating from -15°C to +24°C;
- Automatic protection system Intelligent Preheating. Defrosting “over time” – in average 10 minutes of defrosting for 50 minutes of compressor operation.



Model		CH-S09FHCP	CH-S12FHCP	CH-S18FHCP	CH-S24FHCP
Capacity	Cold kW	2,60 (1,00-3,50)	3,60 (1,00-4,10)	5,00 (1,20-6,30)	6,60 (2,00-8,10)
	Warm kW	2,80 (1,00-4,40)	3,70 (1,10-5,20)	6,00 (1,05-6,70)	7,40 (2,40-8,70)
Power intake	Cold kW	0,81 (0,30-1,40)	1,12 (0,30-1,60)	1,54 (0,40-2,25)	2,19 (0,60-2,70)
	Warm kW	0,78 (0,30-1,50)	1,02 (0,50-1,60)	1,61 (0,40-2,35)	2,05 (0,70-2,90)

INDOOR UNIT

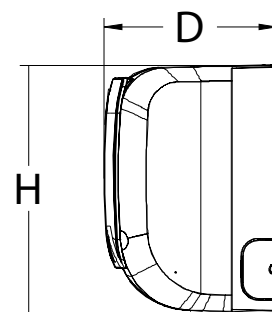
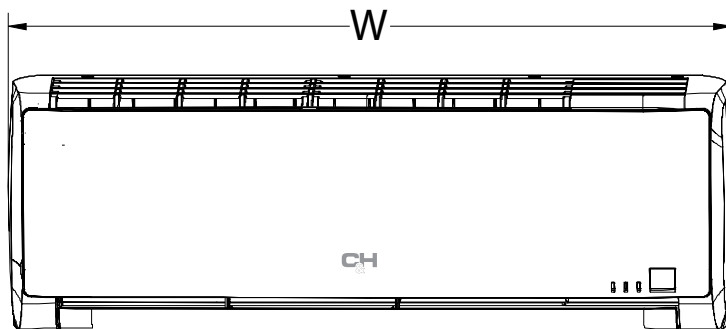

Model	W (mm)	H (mm)	D (mm)
CH-S09FHCP	820	280	195
CH-S12FHCP	820	280	195
CH-S18FHCP	1008	318	225
CH-S24FHCP	1008	318	225

OUTDOOR UNIT

CH-S09FHCP
CH-S12FHCP

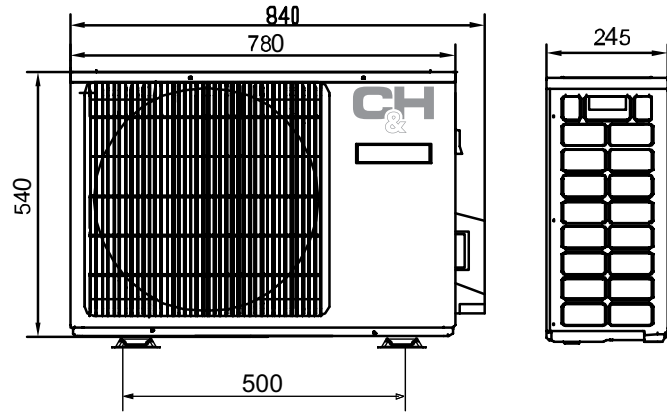
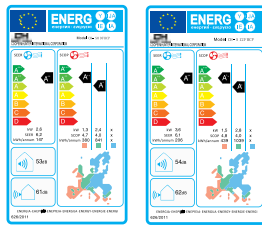

CH-S18FHCP

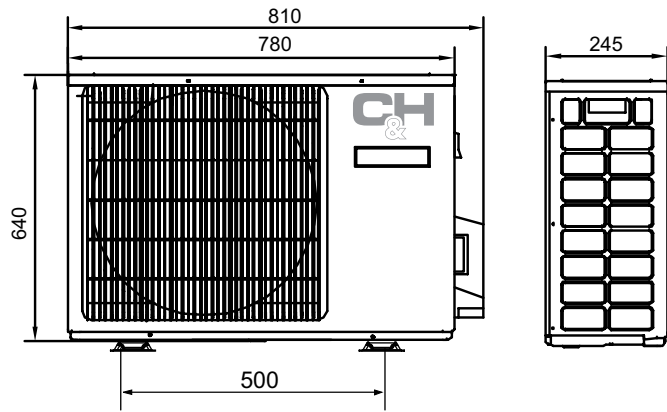

CH-S24FHCP

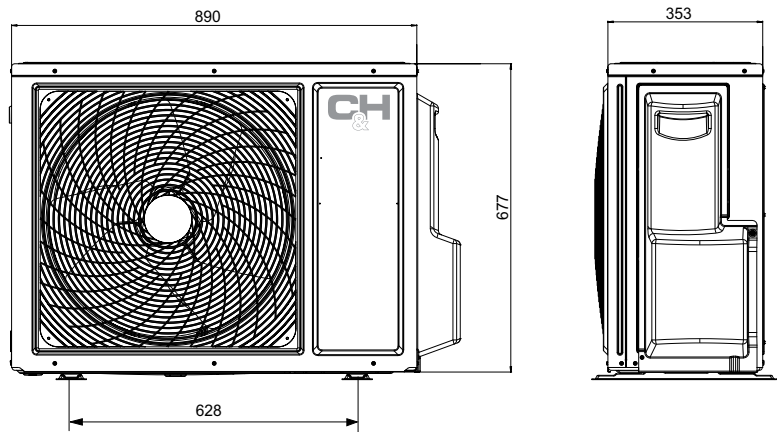
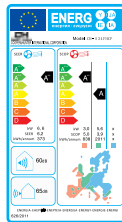

			CH-S09FHCP	CH-S12FHCP	CH-S18FHCP	CH-S24FHCP
Capacity	Cold	kW	2.60 (1.00-3.50)	3.60 (1.00-4.10)	5.00 (1.20-6.30)	6.60 (2.00-8.10)
	Warm	kW	2.80 (1.00-4.40)	3.70 (1.10-5.20)	6.00 (1.05-6.70)	7.40 (2.40-8.70)
Electric power supply						
Rated input	Cold	kW	0.81 (0.30-1.40)	1.12 (0.30-1.60)	1.54 (0.40-2.25)	2.19 (0.60-2.70)
	Warm	kW	0.78 (0.30-1.50)	1.02 (0.50-1.60)	1.61 (0.40-2.35)	2.05 (0.70-2.90)
Seasonal system performance factor	SEER (cooling)	kW / kW	3.21	3.21	3.25	3.01
	SCOP (heating)	kW / kW	3.61	3.63	3.73	3.61
Air productive capacity		m ³ /h	500	550	900	1100
Sound-pressure level	indoor unit	dB (A)	20/26/30/36	20/28/32/37	28/35/37/40	28/36/38/42
	outdoor unit	dB (A)	54	55	58	61
Type of refrigerant coolant			R-410			
Weight	indoor unit	kg	8.8	9	12	12
	outdoor unit	kg	25.5	26	33.5	51
Compressor type			rotor			
Drainage		l/h	1.00	1.20	1.80	2.00
Temperature range	cooling	°C	+10... +43	+10... +43	+10... +43	+10... +43
	heating	°C	-15 ... +24	-15 ... +24	-15 ... +24	-15 ... +24
Weight of refrigerant coolant		kg	0.78	0.78	1.20	1.45
Liquid pipeline diameter		mm/inch	6.38/1/4"	6.38/1/4"	6.38/1/4"	6.38/1/4"
Gas pipeline diameter		mm/inch	9.53/3/8"	9.53/3/8"	12.7/1/2"	12.7/1/2"
Maximum pipeline level difference		m	10	10	15	15
Pipeline maximum length		m	15	15	25	25
Distance between the bolts of the outdoor unit fastening		mm	500	500	500	628

* SEER – Seasonal Energy Efficient Rating in the cooling mode. ** SCOP – seasonal system capacity ratio in the heating mode.

INVERTER CONSOLE SERIES



INVERTER



option

WI-FI



- Wide operating temperature range: cooling from -15°C to +43°C, heating from -25°C to +24°C;
- Slim format (215 mm);
- Wide-angled louvre-boards, control of air supply from the lower and upper parts of the unit;
- Automatic protection system Intelligent Preheating. Defrosting “over time” – in average 10 minutes of defrosting for 50 minutes of compressor operation.



Model		CH-S09FVX	CH-S12FVX	CH-S18FVX
Capacity	Cold	kW 2,60 (0.45-3.20)	3,52 (0.60-3.95)	5,27 (0.90-5.60)
	Warm	kW 2,75 (0.45-3.75)	4,00 (0.60-4.70)	5,5 (0.90-6.60)
Power intake	Cold	kW 0,66 (0.20-1.55)	0,98 (0.22-1.40)	1,42 (0.35-2.50)
	Warm	kW 0,81 (0.20-1.35)	1,00 (0.22-1.58)	1,53 (0.35-2.50)

INDOOR UNIT

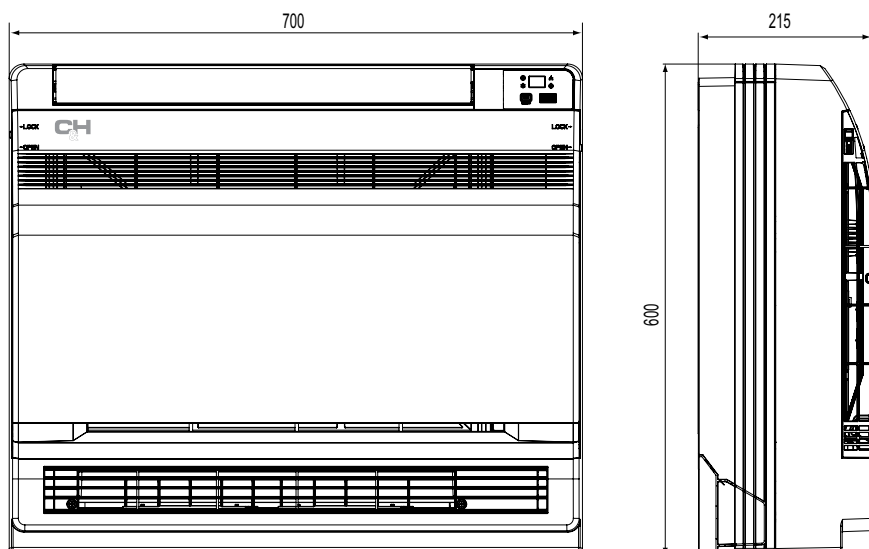

OUTDOOR UNIT

CH-S09FVX
CH-S12FVX (2017)

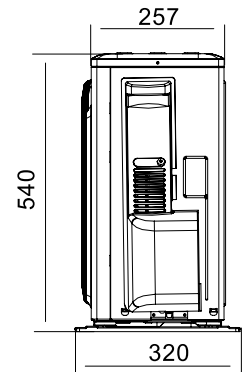
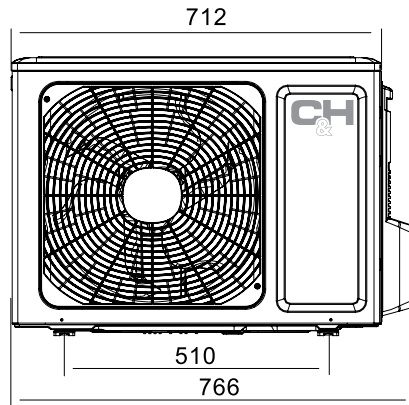
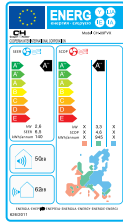

CH-S12FVX

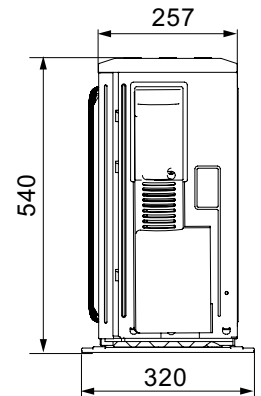
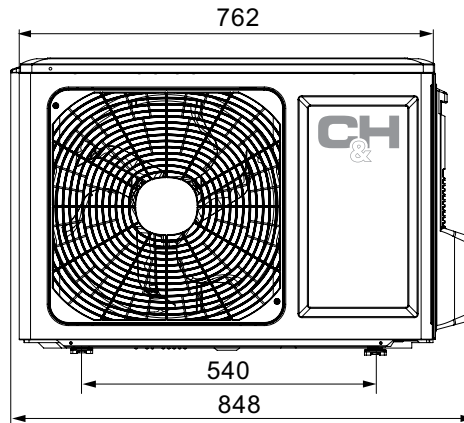
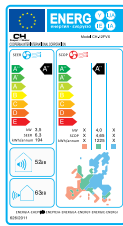

CH-S18FVX
CH-S18FVX (2017)

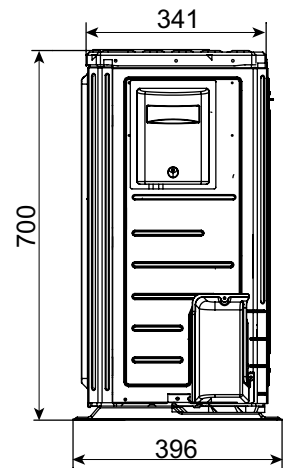
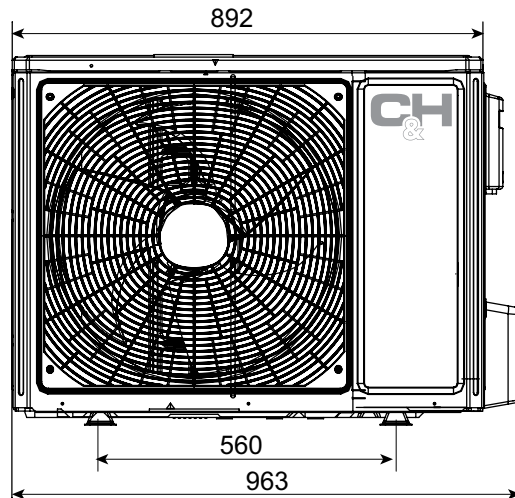
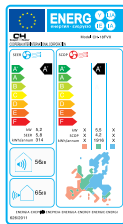

			CH-S09FVX	CH-S12FVX	CH-S18FVX
Capacity	Cold	kW	2.60 (0.45-3.20)	3.52 (0.60-3.95)	5.27 (0.90-5.60)
	Warm	kW	3.30 (0.45-3.75)	4.00 (0.60-4.70)	5.50 (0.90-6.60)
Electric power supply				220-240V/50Hz	
Rated input	Cold	kW	0.66 (0.20-1.55)	0.98 (0.22-1.70)	1.42 (0.35-2.50)
	Warm	kW	0.81 (0.20-1.35)	1.00 (0.22-1.50)	1.53 (0.35-2.50)
Seasonal system performance factor	SEER (cooling)	kW / kW	3.93	3.60	3.46
	SCOP (heating)	kW / kW	4.10	4.00	3.87
Air productive capacity		m ³ /h	500	600	650
Sound-pressure level	indoor unit	dB (A)	22/28/37	24/32/38	28/34/40
	outdoor unit	dB (A)	50	51	53
Type of refrigerant coolant				R-410	
Weight	indoor unit	kg	14	14	14
	outdoor unit	kg	33	33	49
Compressor type				rotor	
Drainage		l/h	1.00	1.20	2.00
Temperature range	cooling	°C	-15 ... +43	-15 ... +43	-15 ... +43
	heating	°C	-25 ... +24	-25 ... +24	-25 ... +24
Weight of refrigerant coolant		kg	0.97	1.05	1.23
Liquid pipeline diameter		mm/inch	6.38/1/4"	6.38/1/4"	6.38/1/4"
Gas pipeline diameter		mm/inch	9.53/3/8"	9.53/3/8"	12.7/1/2"
Maximum pipeline level difference		m	10	10	10
Pipeline maximum length		m	15	15	25
Distance between the bolts of the outdoor unit fastening		mm	510	540	560

* SEER – Seasonal Energy Efficient Rating in the cooling mode. ** SCOP – seasonal system capacity ratio in the heating mode.

PRIMA PLUS SERIES



ON/OFF



- Designed for professional installations
- Extra-low noise level 24 dB
- Innovative indoor unit design
- Remote control with a LED-display
- Highly efficient Ozone-save refrigerant



Model		CH-S07XN7	CH-S09XN7	CH-S12XN7	CH-S18XN7	CH-S24XN7	CH-S30XN7	
Capacity	Cold	kW	2,25	2,55	3,25	4,80	6,15	8,00
	Warm	kW	2,35	2,65	3,40	5,30	6,70	8,50
Power intake	Cold	kW	0,67	0,75	0,98	1,45	1,85	2,48
	Warm	kW	0,63	0,71	0,93	1,46	1,85	2,35

INDOOR UNIT

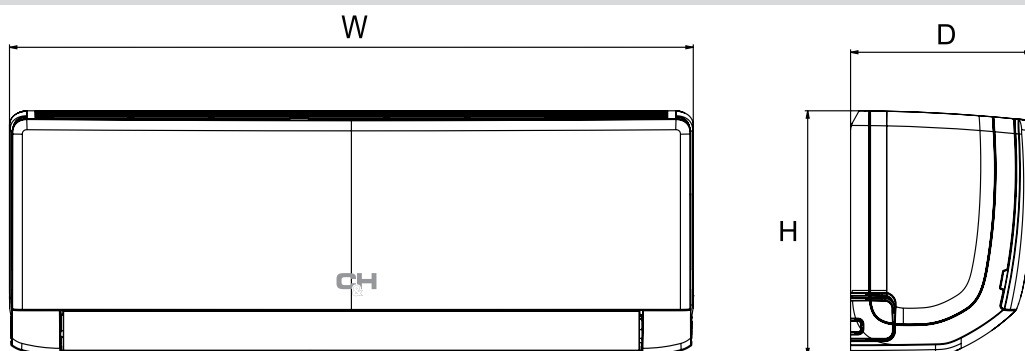

Model	W (mm)	H (mm)	D (mm)
CH-S07XN7	698	250	185
CH-S09XN7	698	250	185
CH-S12XN7	773	250	185
CH-S18XN7	849	289	210
CH-S24XN7	970	300	225
CH-S30XN7	1080	324	245

OUTDOOR UNIT

CH-S07XN7
CH-S09XN7

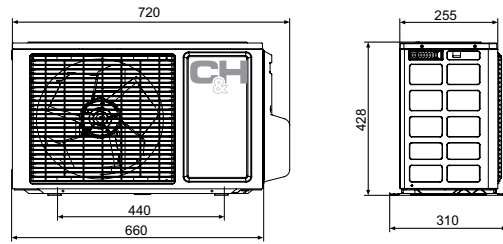

CH-S12XN7

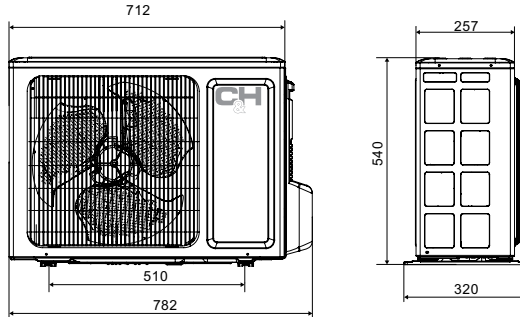

CH-S18XN7

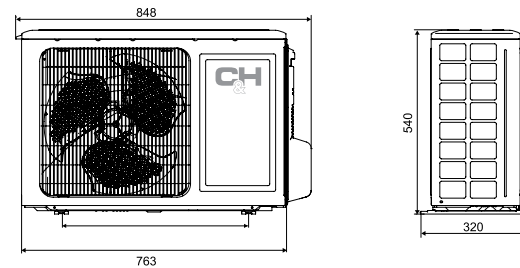

CH-S24XN7

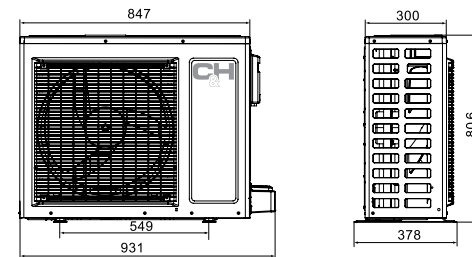

CH-S30XN7

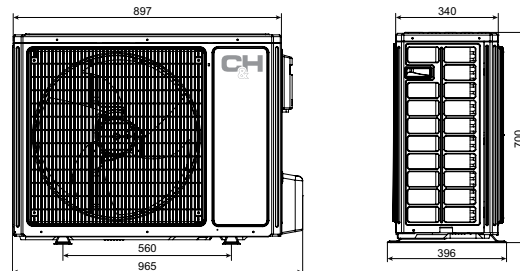

Model			CH-S07XN7	CH-S09XN7	CH-S12XN7	CH-S18XN7	CH-S24XN7	CH-S30XN7
Capacity	Cold	kW	2.25	2.55	3.25	4.80	6.15	8.00
	Warm	kW	2.35	2.65	3.40	5.30	6.70	8.50
Electric power supply			- 220-240V/50Hz					
Rated input	Cold	kW	0.67	0.75	0.98	1.45	1.85	2.48
	Warm	kW	0.63	0.71	0.93	1.46	1.85	2.35
Energy performance	EER (Cold)	kW	3.36	3.38	3.33	3.32	3.32	3.32
	COP (Warm)	kW	3.74	3.73	3.64	3.63	3.62	3.62
Air productive capacity		m ³ /h	470	470	550	650	900	1200
		indoor unit	24/27/31	25/28/33	29/33/35	31/35/39	33/37/41	38/41/44
Sound-pressure level		outdoor unit	47	48	50	52	53	55
	Type of refrigerant coolant	oz	R410A					
Weight	indoor unit	kg	7.5/22	7.5/24.5	8.5/30	11/39	13.5/50	16.5/61
	outdoor unit	kg						
Drainage		l/h	0.60	0.80	1.20	1.80	1.80	3.00
Operational temperature range cooling		°C	+18/+43					
Operational temperature range heating		°C	-7/+24					
Weight of refrigerant coolant		kg	0.55	0.56	0.72	1.26	1.45	1.90
Liquid pipeline diameter		mm/inch	6.38/1/4"	6.38/1/4"	6.38/1/4"	6.38/1/4"	6.38/1/4"	6.38/1/4"
Gas pipeline diameter		mm/inch	9.53/3/8"	9.53/3/8"	12.7/1/2"	12.7/1/2"	12.7/1/2"	15.88/5/8"
Maximum pipeline level difference		m	10					
Pipeline maximum length		m	15	15	15	25	25	30
Distance between the bolts of the outdoor unit fastening		mm	440	440	510	540	549	560

* SEER – Seasonal Energy Efficient Rating in the cooling mode. ** SCOP – seasonal system capacity ratio in the heating mode.

AIR-MASTER PLUS

SERIES



ON/OFF

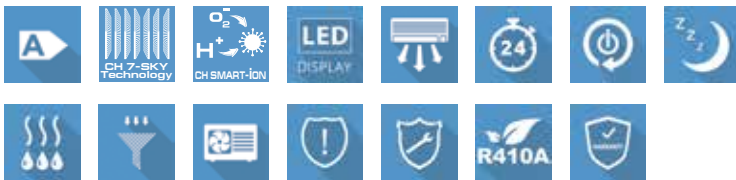

- Increased operational life
- Heat exchangers have the anti-corrosion coating GREEN-FIN
- Wide angle louvers, that create a coverage of the entire space powered by the automatic function SWING



Model		CH-S07XP7	CH-S09XP7	CH-S12XP7	CH-S18XP7	CH-S24RP7
Capacity	Cold kW	2,26	2,70	3,25	4,7	6,15
	Warm kW	2,43	2,85	3,40	4,9	6,50
Power intake	Cold kW	0,69	0,82	1,00	1,46	1,9
	Warm kW	0,66	0,78	0,97	1,43	1,9

INDOOR UNIT

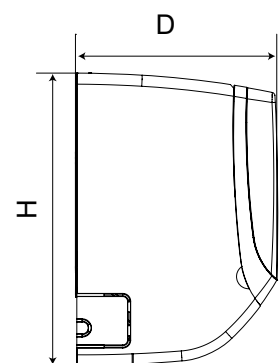
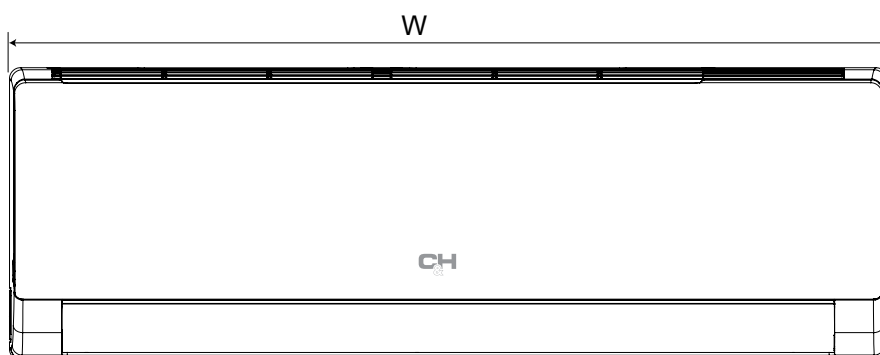

Model	W (mm)	H (mm)	D (mm)
CH-S07XP7	730	254	184
CH-S09XP7	730	254	184
CH-S12XP7	848	275	190
CH-S18XP7	945	298	211
CH-S24XP7	945	298	211

OUTDOOR UNIT

CH-S07XP7
CH-S09XP7

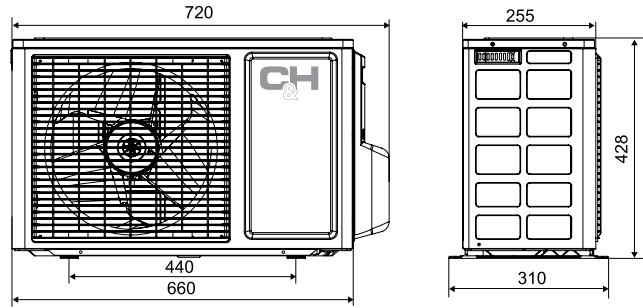

CH-S12XP7

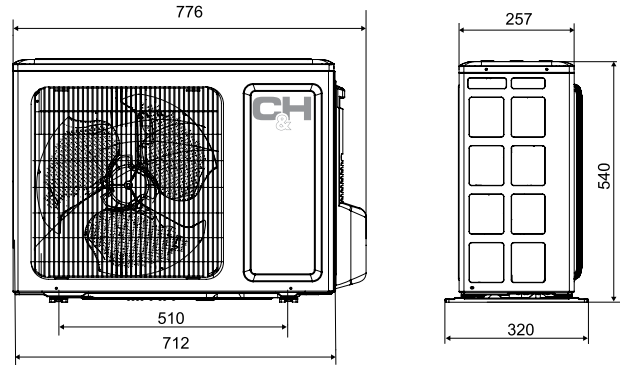

CH-S18XP7

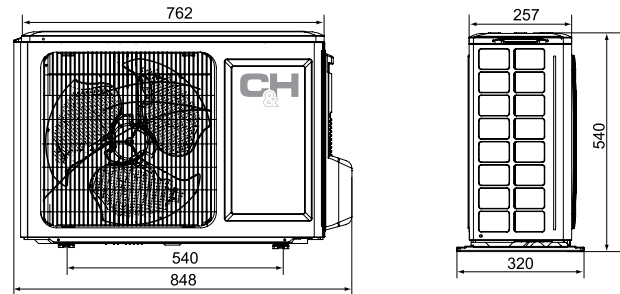

CH-S24XP7

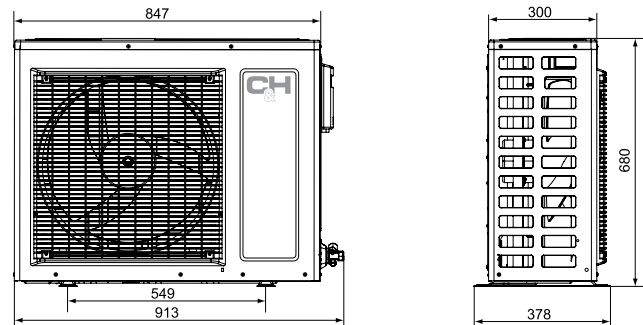

			CH-S07XP7	CH-S09XP7	CH-S12XP7	CH-S18XP7	CH-S24XP7
Capacity	Cold	kW	2,26	2,70	3,25	4,70	6,15
	Warm	kW	2,43	2,85	3,40	4,90	6,50
Electric power supply							
Rated input	Cold	kW	0,69	0,82	1,00	1,46	1,9
	Warm	kW	0,66	0,78	0,97	1,43	1,9
Seasonal system performance factor	SEER (cooling)	kW / kW	3,28	3,29	3,25	3,22	3,24
	SCOP (heating)	kW / kW	3,68	3,65	3,51	3,43	3,42
Air productive capacity		m ³ /h	400	400	600	850	850
Sound-pressure level	indoor unit	dB (A)	24/27/31	26/31/33	29/33/35	31/35/39	33/37/41
	outdoor unit	dB (A)	49	49	50	52	53
Type of refrigerant coolant			R-410				
Weight	indoor unit	kg	8	8	10	13	13
	outdoor unit	kg	22	26	29	40	50
Compressor type			rotor				
Drainage		l/h	0,60	0,80	1,20	1,80	2,00
Temperature range	cooling	°C	+18... +43	+18... +43	+18... +43	+18... +43	+18... +43
	heating	°C	-7 ... +24	-7 ... +24	-7 ... +24	-7 ... +24	-7 ... +24
Weight of refrigerant coolant		kg	0,61	0,75	0,80	1,15	1,45
Liquid pipeline diameter		mm/inch	6.38/1/4"	6.38/1/4"	6.38/1/4"	6.38/1/4"	6.38/1/4"
Gas pipeline diameter		mm/inch	9.53/3/8"	9.53/3/8"	12.7/1/2"	12.7/1/2"	12.7/1/2"
Maximum pipeline level difference		m	5	10	10	10	10
Pipeline maximum length		m	15	15	20	25	25
Distance between the bolts of the outdoor unit fastening		mm	440	440	510	540	549

* SEER – Seasonal Energy Efficient Rating in the cooling mode. ** SCOP – seasonal system capacity ratio in the heating mode.

ECOSTAR SERIES



ON/OFF



- Exclusive modern design of the indoor unit will not leave anyone indifferent.
- The smooth lines and the golden color of the front panel will beautify the most fashionable interior.
- Increased operational life
- Heat exchangers have the anti-corrosion coating GREEN-FIN
- Wide angle louvers, that create a coverage of the entire space powered by the automatic function SWING



Model			CH-S07GKP8	CH-S09GKP8	CH-S12GKP8	CH-S18GKP8	CH-S24GKP8	CH-S30GKP8
Capacity	Cold	kW	2.25	2.55	3.25	4.80	6.15	8.00
	Warm	kW	2.35	2.65	3.40	5.30	6.70	8.50
Rated input	Cold	kW	0.70	0.79	1.01	1.49	1.91	2.85
	Warm	kW	0.65	0.73	0.94	1.47	1.86	2.65

INDOOR UNIT

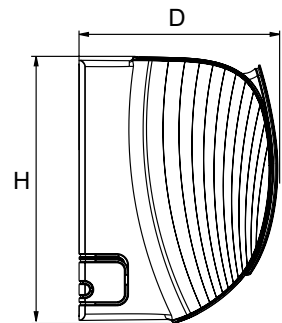
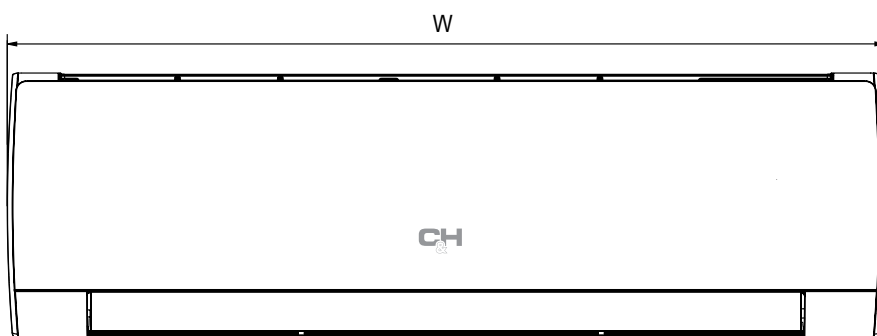

Model	W (mm)	H (mm)	D (mm)
CH-S07GKP8	744	256	185
CH-S09GKP8	744	256	185
CH-S12GKP8	819	256	185
CH-S18GKP8	888	294	212
CH-S24GKP8	1013	307	221
CH-S30GKP8	1013	307	221

OUTDOOR UNIT

CH-S07GKP8
CH-S09GKP8

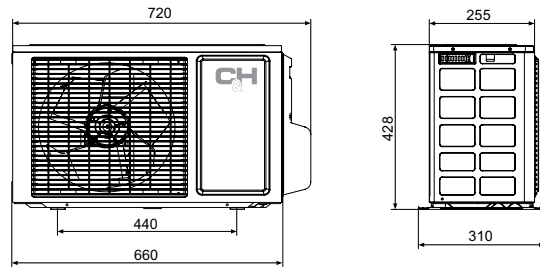

CH-S12GKP8

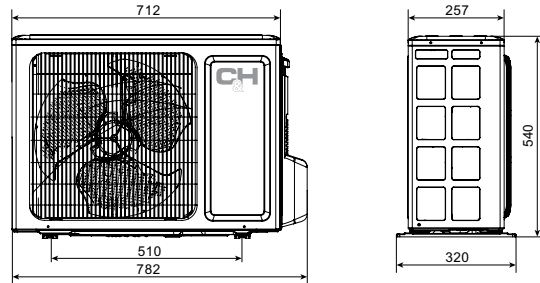

CH-S18GKP8

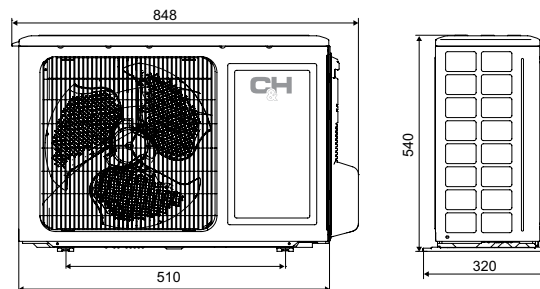

CH-S24GKP8

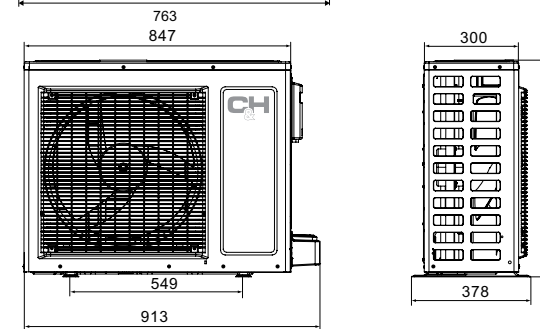

CH-S30GKP8

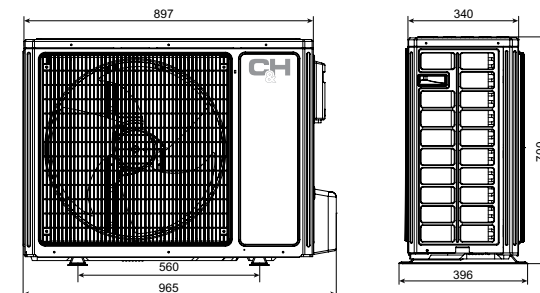

Model			CH-S07GKP8	CH-S09GKP8	CH-S12GKP8	CH-S18GKP8	CH-S24GKP8	CH-S30GKP8
Capacity	Cold	kW	2.25	2.55	3.25	4.80	6.15	8.00
	Warm	kW	2.35	2.65	3.40	5.30	6.70	8.50
Electric power supply			-220-240V/50Hz					
Rated input	Cold	kW	0.70	0.79	1.01	1.49	1.91	2.85
	Warm	kW	0.65	0.73	0.94	1.47	1.86	2.65
Energy performance	EER (Cold)	kW	3.21	3.23	3.22	3.22	3.22	2.81
	COP(Warm)	kW	3.62	3.63	3.62	3.61	3.61	3.21
Air productive capacity		m ³ /h	470	470	550	650	900	1200
		indoor unit	26/28/31	26/31/33	29/33/35	31/34/38	37/39/41	39/42/44
Sound-pressure level		outdoor unit	49	49	50	56	56	59
	Type of refrigerant coolant	oz	R410A					
Drainage	l/h	0.60	0.80	1.20	1.80	1.80	3.00	
Operational temperature range cooling	°C	+18/+43						
Operational temperature range heating	°C	-7/+24						
Weight of refrigerant coolant	kg	0.55	0.56	0.72	1.26	1.45	1.90	
Liquid pipeline diameter	mm/inch	6.38/1/4"	6.38/1/4"	6.38/1/4"	6.38/1/4"	6.38/1/4"	6.38/1/4"	
Gas pipeline diameter	mm/inch	9.53/3/8"	9.53/3/8"	12.7/1/2"	12.7/1/2"	12.7/1/2"	15.88/5/8"	
Maximum pipeline level difference	m	10						
Pipeline maximum length	m	15	15	15	25	25	30	
Distance between the bolts of the outdoor unit fastening	mm	440	440	510	540	549	560	

* SEER – Seasonal Energy Efficient Rating in the cooling mode. ** SCOP – seasonal system capacity ratio in the heating mode.

ECO PLAZMA SERIES



ON/OFF

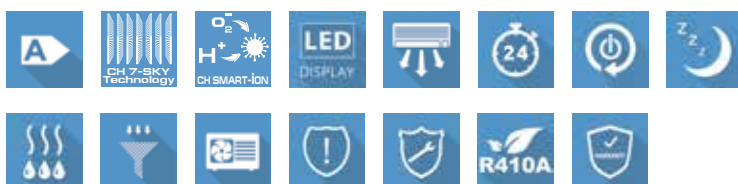

- Indoor unit can be produced in two colors: silver (MKP6), black (BKP6);
- Heat exchangers have the anti-corrosion coating GREEN-FIN;
- Dehumidifying function, without decreasing of a temperature;
- Automatic restart with memory settings.

Model		CH-S07MKP6/CH-S07BKP6	CH-S09MKP6/CH-S09BKP6	CH-S12MKP6/CH-S12BKP6
Capacity	Cold kW	2,26	2,70	3,25
	Warm kW	2,43	2,85	3,40
Power intake	Cold kW	0,69	0,82	1,00
	Warm kW	0,66	0,78	0,97

INDOOR UNIT

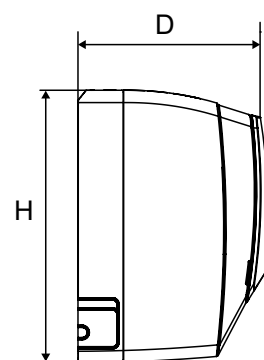
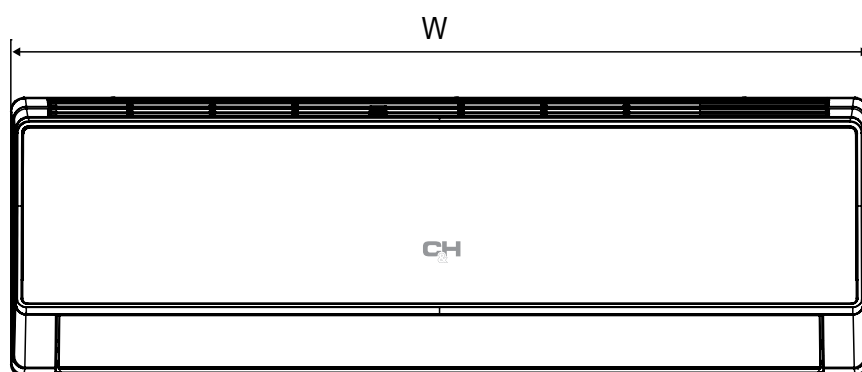

Model	W (mm)	H (mm)	D (mm)
CH-S07MKP6/CH-S07BKP6	730	255	170
CH-S09MKP6/CH-S09BKP6	730	255	170
CH-S12MKP6/CH-S12BKP6	845	275	180

OUTDOOR UNIT

CH-S07MKP6/CH-S07BKP6
CH-S09MKP6/CH-S09BKP6

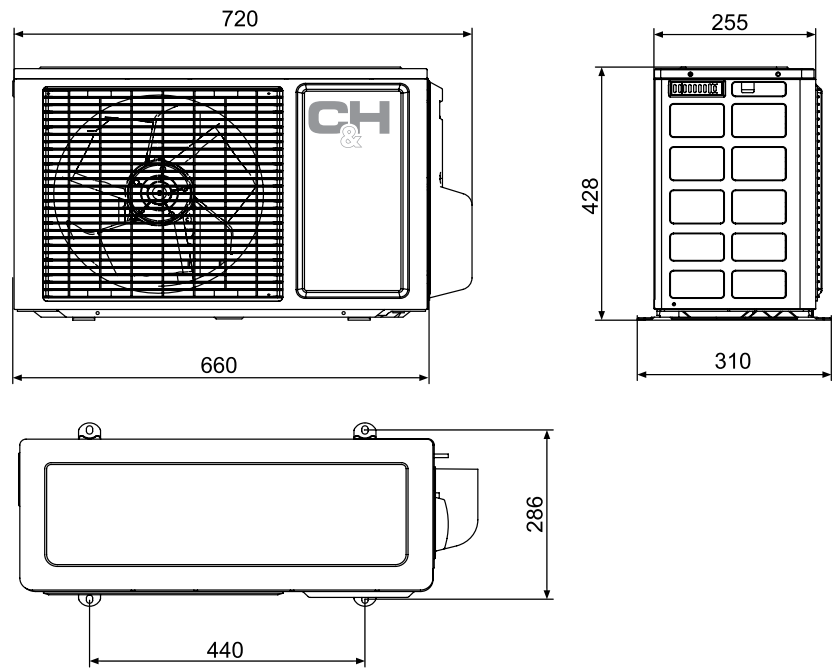

CH-S12MKP6/CH-S12BKP6

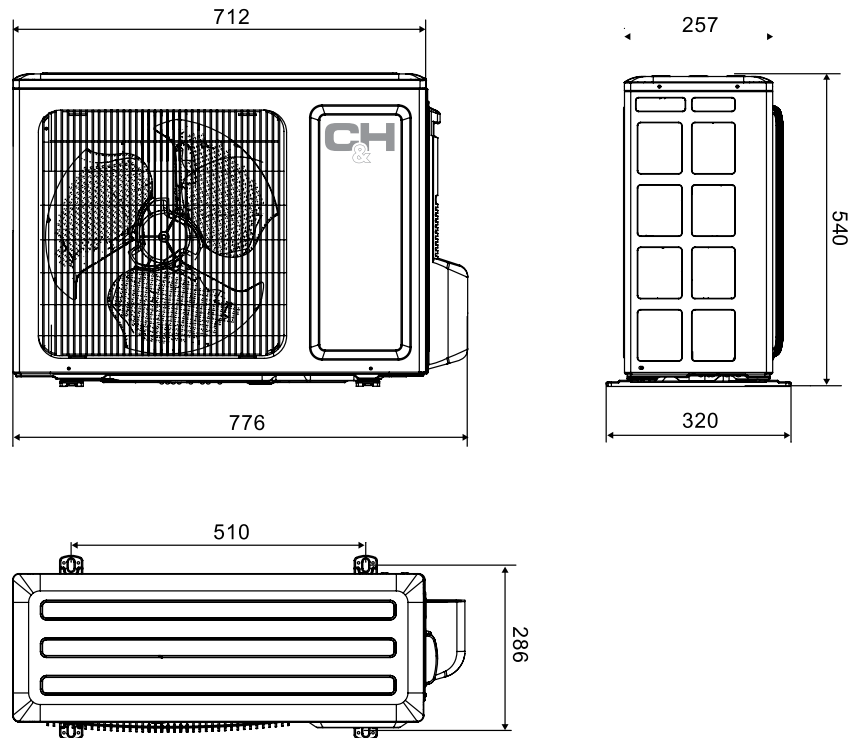

			CH-S07MKP6/CH-S07BKP6	CH-S09MKP6/CH-S09BKP6	CH-S12MKP6/CH-S12BKP6
Capacity	Cold	kW	2,26	2,70	3,25
	Warm	kW	2,43	2,85	3,40
Electric power supply					
Rated input	Cold	kW	0,69	0,82	1,00
	Warm	kW	0,66	0,78	0,97
Seasonal system performance factor	SEER (cooling)	kW / kW	3,28	3,29	3,25
	SCOP (heating)	kW / kW	3,68	3,65	3,51
Air productive capacity		m ³ /h	400	400	550
Sound-pressure level	indoor unit	dB (A)	24/27/31	26/31/33	29/33/35
	outdoor unit	dB (A)	49	49	50
Type of refrigerant coolant			R-410		
Weight	indoor unit	kg	8	8	9
	outdoor unit	kg	22	25,5	29
Drainage		l/h	0,60	0,80	1,20
Temperature range	cooling	°C	+18... +43	+18... +43	+18... +43
	heating	°C	-7 ... +24	-7 ... +24	-7 ... +24
Weight of refrigerant coolant		kg	0,5	0,68	0,80
Liquid pipeline diameter		mm/inch	6.38/1/4"	6.38/1/4"	6.38/1/4"
Gas pipeline diameter		mm/inch	9.53/3/8"	9.53/3/8"	12.7/1/2"
Maximum pipeline level difference		m	5	10	10
Pipeline maximum length		m	15	15	20
Distance between the bolts of the outdoor unit fastening		mm	440	440	510

* SEER – Seasonal Energy Efficient Rating in the cooling mode. ** SCOP – seasonal system capacity ratio in the heating mode.

MONOBLOCK



INVERTER



- No bulky outdoor unit, modern stylish design
- Simple and economic installation process
- Can be installed on the top of the wall or on the bottom
- Noiseless operation for ideal sleep
- Sensor screen for convenient control
- Built-in Wi-Fi control

		CH-VC11TH	CH-VC13TH
Cooling capacity	kW	2.04	2.35
Maximum cooling capacity. Double power	kW	2.60	3.10
Heating capacity (2)	kW	2.10	2.36
Heating capacity (3)	kW	0.98	1.11
Maximum heating capacity. Double power	kW	2.64	3.05
Rated input on cooling (1)	kW	0.63	0.73
Rated input on heating (2)	kW	0.638	0.72
Drying capacity	l/h	1.0	1.1
Power supply	V-Ph-Hz	230-1-50	230-1-50
EER	Wt/Wt	3.24	3.22
COP	kW/kW	3.29	3.28
Energy-efficient cooling class		A+	A+
Energy-efficient heating class		A	A
Internal - external ventilation speed	No.	3	3
Internal - External air flow at maximum speeds	m ³ /h	380/460	400/480
Internal-External Airflow with medium speed	m ³ /h	310/380	320/390
Internal -External air flow at minimum speed	m ³ /h	260/330	270/340
Dimensions (WxHxD)	mm	1030x555x170	1030x555x170
Weight including packaging	kg	48.5	48.5
Sound pressure level (min-max.) (4)	dB (A)	26/39	27/41
The sound power level of the device inside (min-max.) (5)	dB (A)	44/57	45/58
Diameter of wall holes	mm	162	162
Distance of wall holes	mm	293	293
Refrigerant gas		R410A	
Amount of refrigerant R410A	gr.	560	560
Total heating potential (GWP 2088)	kgCO ₂ eq.	1,169	1,169
Maximum capacity consumption	kW	0.950*	1,060*
Maximum current consumption	A	4.4*	4.8*
Maximum working pressure PS	MPa	3.8	3.8
Degree of protection		IPX0	IPX0

* With dual power function, which activates during heating process

Baseline conditions	Room T	External T
(1) Cooling mode tests (EN 14511)	DB 27°C - WB 19°C	DB 35°C - WB 24°C
(2) Heating mode tests (EN 14511)	DB 20°C - WB 15°C	DB 7°C - WB 6°C
(3) Heating mode tests	DB 20°C - WB 15°C	DB -7°C - WB -8°C

(4) Internal sound pressure, measured in a semi-anechoic chamber at a distance of 2 m.
 (5) The internal sound pressure, measured in accordance with EN 12012

* SEER – Seasonal Energy Efficient Rating in the cooling mode. ** SCOP – seasonal system capacity ratio in the heating mode.

PORTABLE AIR CONDITIONER



CH-M09K6S
CH-M10K7B
CH-M12K7S



- Low Noise level «More Silence»;
- 5-layer guard shield «V-protect»;
- 0,5W Standby;
- Vertical swing.

Model		CH-M09K6S	CH-M10K7B	CH-M12K7S
Capacity	Cold kW	2,64	2,93	3,52
	Warm kW	-	2,93	3,52
Power intake	Cold kW	1,01	0,95	1,35
	Warm kW	-	0,90	1,24

CH-M09K6S
CH-M10K7B
CH-M12K7S

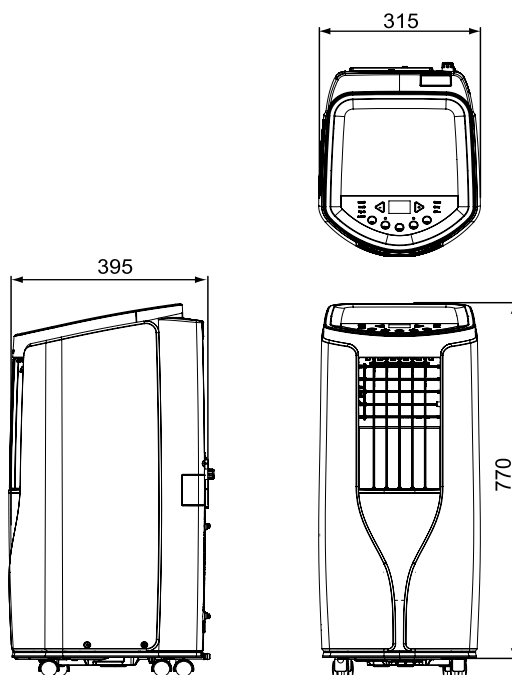
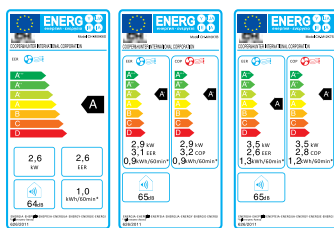

Model	Power supply	Type of refrigerant	Energy Efficiency EER (cooling)	Energy Efficiency COP (heating)	Airflow	Noise level (min/avg/max) dB (A)
	V/Hz/Ph		KW/KW	KW/KW		
CH-M09K6S	-220-240V/50Hz/1Ph	R32	2,62	-	330/300/270	46/48/51
CH-M10K7B	-220-240V/50Hz/1Ph	R32	3,1	3,2	360/330/300	46/48/51
CH-M12K7S	-220-240V/50Hz/1Ph	R410A	2,61	2,85	360/330/300	47/49/51



COMMERCIAL SERIES
FOR PROFESSIONAL
INSTALLATION



NORDIC COMMERCIAL DUCT TYPE SERIES



INVERTER



- Compact size;
- Drainage pump (only for inverter models);
- Low noise level;
- Long life washable filter;
- Self-diagnosis of the main units and modes;
- Multi-level protection system;
- Intelligent defrost;
- Length of the pipe up to 50 m.

Model	CH-ID09NK4 / CH-IU09NK4	CH-ID12NK4 / CH-IU12NK4	CH-ID18NK4 / CH-IU18NK4	CH-ID24NK4 / CH-IU24NK4	CH-ID30NK4 / CH-IU30NK4
Capacity Cooling/heating kW	2.7/2.9	3.50/3.80	5.0/5.6	7.00/8.00	8.3/9.2
Power Supply	- 220-240V/50Hz -/1Ph	- 220-240V/50Hz -/1Ph	- 220-240V/50Hz -/1Ph	- 220-240V/50Hz -/1Ph	- 220-240V/50Hz -/1Ph

Model	CH-ID36NK4 / CH-IU36NM4	CH-ID42NK4 / CH-IU42NM4	CH-ID48NK4 / CH-IU48NM4	CH-ID60NK4 / CH-IU60NM4
Capacity Cooling/heating kW	10.00/12.00	11.50/13.50	14.00/15.50	16.00/16.50
Power Supply	- 380-415V/50Hz -/3Ph	- 380-415V/50Hz -/3Ph	- 380-415V/50Hz -/3Ph	- 380-415V/50Hz -/3Ph

INDOOR UNIT

CH-ID09NK4 – CH-ID18NK4

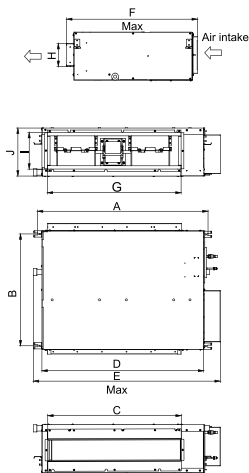

CH-D24NK2 – CH-D60NK2
CH-ID24NK4 – CH-ID60NK4

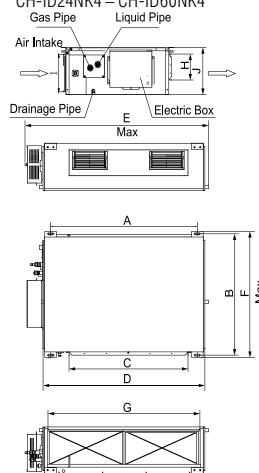

CH-D18NK2*

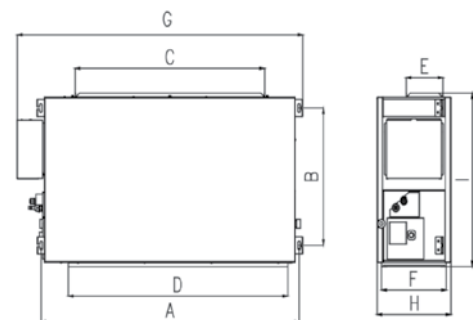

INVERTER

ON/OFF

Model	A (mm)	B (mm)	C (mm)	D (mm)	E (mm)	F (mm)	G (mm)	H (mm)	I (mm)	J (mm)
CH-ID09NK4	840	561	635	790	925	665	738	125	203	250
CH-ID12NK4	945	618	738	892	1037	721	738	125	203	266
CH-ID18NK4	1101	517	820	1159	1279	558	1002	160	235	268
CH-ID24NK4	1011	748	820	1115	1226	775	979	160	231	290
CH-ID30NK4	1177	646	852	1150	1340	750	953	190	316	350
CH-D18NK2*	940	430	740	738	206	125	1015	275	720	-
CH-D24NK2	1011	515	820	1159	1260	555	1002	160	235	270
CH-D36NK2	1011	748	820	1115	1226	775	979	160	231	290
CH-D48NK2	1011	788	820	1115	1235	830	979	160	256	330

OUTDOOR UNIT

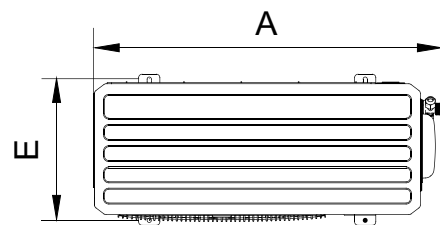
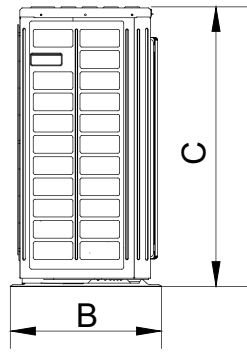
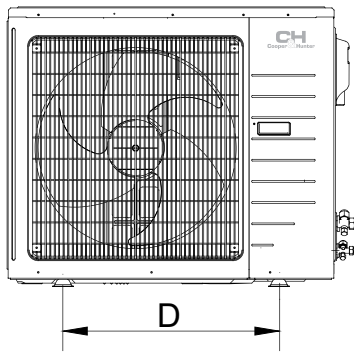

INVERTER

Model	A (mm)	B (mm)	C (mm)	D (mm)	E (mm)
CH-IU09NK4 CH-IU12NK4	848	320	540	540	286
CH-IU18NK4	955	396	700	560	360
CH-IU24NK4 CH-IU30NK4	980	427	790	610	395
CH-IU36NM4	1107	440	1100	631	400
CH-IU42NM4 CH-IU48NM4	958	412	1349	572	376
CH-IU60NM4	1085	427	1365	620	395

ON/OFF

Model	A (mm)	B (mm)	C (mm)	D (mm)	E (mm)
CH-U18NK2 CH-U24NK2	955	395	700	560	360
CH-U36NM2	980	425	790	610	395
CH-U48NM2	1120	440	1100	631	400
CH-U60NM2	980	410	1350	572	376

Model	ON/OFF	CH-D18NK2/ CH-U18NK2	CH-D24NK2/ CH-U24NK2	CH-D36NK2/ CH-U36NM2	CH-D48NK2/ CH-U48NM2	CH-D60NK2/ CH-U60NM2	
Capacity	Cold/warm	kW	5.00/5.40	7.00/7.40	10.00/11.50	14.00/15.00	16.00/18.00
Electric power supply			-220-240V/50Hz/1Ph			-380-415V/50Hz/3Ph	
Rated input	Cold/warm	kW	2.00/1.90	2.50/2.30	3.60/3.30	5.00/4.70	5.60/5.50
Current rate	Cold/warm	A	9.20/8.20	12.00/10.50	7.60/7.20	10.80/10.50	11.60/11.40
Energy performance	Cold/warm	EER/COP	2.50/2.80	2.80/3.20	2.70/3.40	2.80/3.10	2.80/3.20
Air productive capacity		m³/h	720/660/540/420	1260/1000/780/660	2100/2030/1860/1730	2300/2100/1750/1650	2500/2300/1900/1800
Pressure range	Indoor unit	Pa	0-30	0-40	0-75	0-100	0-100
	Outdoor unit		36/33/30/29	43/38/34/32	51/48/46/44	53/52/50/50	56/52/49/49
Sound-pressure level	Indoor unit	dB (A)	56	59	60	60	61
Type of refrigerant coolant			R410a				
Weight	Indoor unit/ outdoor unit	kg	31/53	33/61	46/69	53/103	56/118
Volume of refrigerant coolant		Kg	1.30	1.50	2.20	3.70	4.10
Operational temperature range	Cold/warm	°C	-15 – +43/-15 – +24				
Liquid pipeline diameter		mm/inch	6.35/ 1/4"	9.53/ 3/8"	9.53/ 3/8"	12.70 / 1/2"	12.70 / 1/2"
Gas pipeline diameter		mm/inch	12.7 / 1/2»	15.88 / 5/8"	19.05 / 3/4»	19.05 / 3/4»	19.05 / 3/4»
Maximum pipeline level difference		m	15			30	15
Pipeline maximum length		m	15			30	50
Distance between the both of the outdoor unit fastening		mm	560			610	572
Number of interblock strands (for control)			2*0.75 up to 20 m			2*1.0 – if longer than 20 m	
Main power supply area			outdoor				
Number of the strands (power supply)	Indoor unit/ outdoor unit		3(∅1.0mm)/ 3(∅4.0mm)	3(∅1.0mm)/ 3(∅4.0mm)	3(∅1.5mm)/ 5(∅2.5mm)	3(∅1.5mm)/ 5(∅4.0mm)	3(∅1.5mm)/ 5(∅4.0mm)
Factory Freon fill (for the number of the running meters)		r. m.	7				
Freon per one running meter (surplus. for one running meter)		gr/r.m.	22	54	110	110	110

Model	INVERTER	CH-ID09NK4 / CH-IU09NK4	CH-ID12NK4 / CH-IU12NK4	CH-ID18NK4 / CH-IU18NK4	CH-ID24NK4 / CH-IU24NK4	CH-ID30NK4 / CH-IU30NK4	CH-ID36NK4 / CH-IU36NM4	CH-ID42NK4 / CH-IU42NM4	CH-ID48NK4 / CH-IU48NM4	CH-ID60NK4 / CH-IU60NM4	
Capacity	Cold/Warm	kW	2.7/2.9	3.50/3.80	5.0/5.6	7.00/8.00	8.3/9.2	10.00/12.00	11.50/13.50	14.00/15.50	16.00/16.50
Electric power supply			-220-240V/50Hz/1Ph								
Rated input	Cold/Warm	kW	0.84/0.8	1.17/1.05	1.55/1.55	2.18/2.21	2.67/2.57	3.12/3.32	4.0/3.9	5.1/4.5	5.6/4.57
Input rate	Cold	A	3.9	5.40	7.50	10.10	12.4	5.40	6.90	8.80	9.7
	Warm		3.7	4.90	7.40	10.20	12.0	5.80	6.70	7.80	7.9
Energy performance	Cold/Warm	EER/COP	3.21/3.61	3.0/3.61	3.23/3.61	3.21/3.62	3.11/3.58	3.21/3.61	2.88/3.46	2.75/3.44	2.86/3.61
Air capability	Indoor unit	m³/h	650	750	1000	1400	1400	2100	2100	2400	3000
Nominal pressure	Indoor unit	Pa	25	25	25	25	37	37	37	50	50
Pressure level	Indoor unit	Pa	0-30	0-35	0-35	0-75	0-75	0-100	0-100	0-125	0-150
Sound-pressure level	Indoor unit	dB (A)	36/34/28/26	37/36/34/28	40/39/36/28	47/46/44/40	47/46/44/40	53/52/48/44	53/52/48/44	55/53/49/45	57/56/54/49
	outdoor unit		52	52	56	57	58	63	61	59	63
Type of refrigerant coolant			R410A								
Refrigerant coolant		kg	1.2	1.2	1.4	2.2	2.4	3.5	3.7	4.0	5.0
Weight	Indoor unit/ outdoor unit	kg	27/34	33/34	33/47	34/67	34/71	46/98	46/108	56/114	57/126
Operational temperature range	Cold	°C	-15/+48								
	Warm	°C	-20/+24								
Liquid pipeline diameter		mm/inch	6.38/ 1/4"	6.38/ 1/4"	6.38/ 1/4"	9.53/ 3/8"	9.53/ 3/8"	9.53/ 3/8"	9.53/ 3/8"	9.53/ 3/8"	9.53/ 3/8"
Gas pipeline diameter		mm/inch	9.53/ 3/8"	9.53/ 3/8"	12.70/ 1/2"	15.88/ 5/8"	15.88/ 5/8"	15.88/ 5/8"	15.88/ 5/8"	15.88/ 5/8"	19.05/ 3/4"
Maximum pipeline level difference		m	15			30		15	30		
Pipeline maximum length		m	20			30		30	50		
Quantity of interblock strands (for control)			2*0.75 – up to 20 m long				2*1.0 – if longer than 20 m		2*1.0 – if longer than 20 m		
Main power supply area			outdoor.								
Quantity of the strands (powersupply outdoor/indoor)	Indoor unit		3(∅1.0 mm)	3(∅1.0 mm)	3(∅1.0 mm)	3(∅1.0 mm)	3(∅1.0 mm)	3(∅1.0 mm)	3(∅1.0 mm)	3(∅1.0 mm)	3(∅1.0 mm)
	Outdoor unit		3(∅1.5 mm)	3(∅1.5 mm)	3(∅2.5 mm)	3(∅2.5 mm)	3(∅2.5 mm)	5(∅1.5 mm)	5(∅2.5 mm)	5(∅2.5 mm)	5(∅2.5 mm)
Factory Freon fill (per the number of running meters)		m.	5								
Volume of freon.		gramm/m.p.	30	30	30	60	60	60	60	60	60
SEER/SCOP			5.6/3.8	5.6/4.0	5.6/3.8	6.1/4.0	6.1/4.0	5.1/4.0	5.6/4.0	5.6/3.8	5.6/3.8

* SEER – Seasonal Energy Efficient Rating in the cooling mode. ** SCOP – seasonal system capacity ratio in the heating mode.

NORDIC COMMERCIAL CASSETTE TYPE SERIES



INVERTER



- Compact size;
- Drainage pump (only for inverter models);
- Low noise level;
- Long life washable filter;
- Automatic air distribution in Swing mode
- Self-diagnosis of the main units and modes;
- Multi-level protection system;
- Intelligent defrost;
- Length of the pipe up to 50 m.

Model	CH-IC12NK4/ CH-IU12NK4	CH-IC18NK4/ CH-IU18NK4	CH-IC24NK4/ CH-IU24NK4	CH-IC36NK4/ CH-IU36NM4	CH-IC42NK4/ CH-IU42NM4	CH-IC48NK4/ CH-IU48NM4	CH-IC60NK4/ CH-IU60NM4
Capacity Cooling/heating kW	3.5/3.8	5.0/5.5	7.0/8.0	10.0/12.0	11.0/12.5	14.0/16.0	16.0/17.0
Power Supply	- 220-240V/50Hz/1Ph	- 220-240V/50Hz/1Ph	- 220-240V/50Hz/1Ph	- 380-415V/50Hz/3Ph	- 380-415V/50Hz/3Ph	- 380-415V/50Hz/3Ph	- 380-415V/50Hz/3Ph

INDOOR UNIT

Model	A (mm)	B (mm)	C (mm)	D (mm)	E (mm)	F (mm)	G (mm)	H (mm)	I (mm)	J (mm)
CH-C18NK2	670	595	599	562	135	240	665	234	562	491

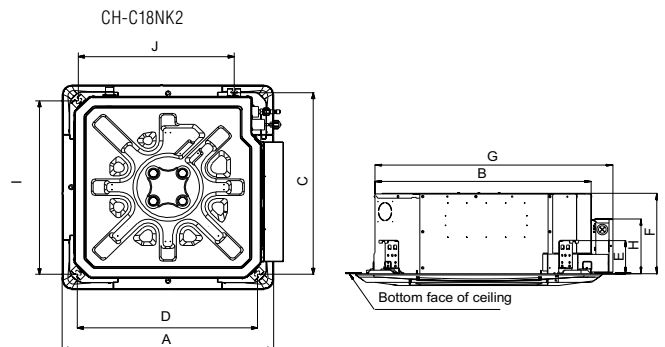
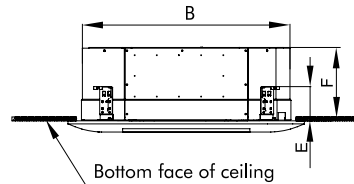
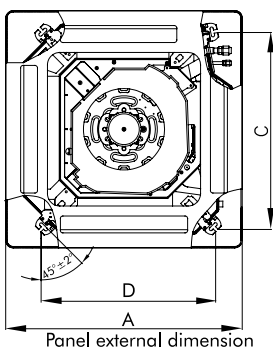

INVERTER

Model	A (mm)	B (mm)	C (mm)	D (mm)	E (mm)	F (mm)
CH-IC12NK4 CH-IC18NK4	670	596	592	571	145	240
CH-IC24NK4	950	840	780	680	160	240
CH-IC36NK4 CH-IC42NK4	950	840	780	680	160	320
CH-IC48NK4 CH-IC60NK4	1040	910	842	788	170	290

ON/OFF

Model	A (mm)	B (mm)	C (mm)	D (mm)	E (mm)	F (mm)
CH-C24NK4	950	840	784	728	135	240
CH-C36NK4 CH-C48NK4	950	850	776	712	134	325
CH-C60NK4	950	840	770	680	134	290

OUTDOOR UNIT

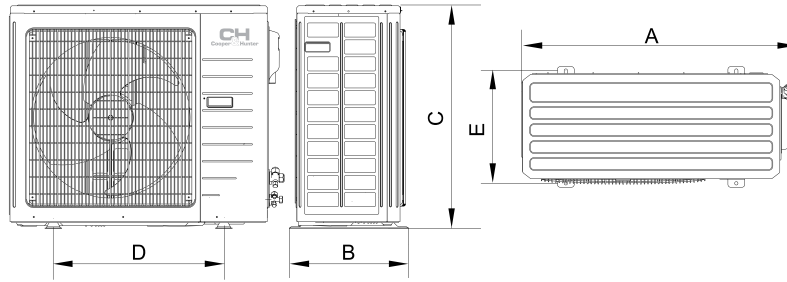

INVERTER

Model	A (mm)	B (mm)	C (mm)	D (mm)	E (mm)
CH-IU12NK4	848	320	540	540	286
CH-IU18NK4	955	396	700	560	360
CH-IU24NK4	980	427	790	610	395
CH-IU30NK4					
CH-IU36NM4	1107	440	1100	631	400
CH-IU42NM4	958	412	1349	572	376
CH-IU48NM4					
CH-IU60NM4	1085	427	1365	620	395

ON/OFF

Model	A (mm)	B (mm)	C (mm)	D (mm)	E (mm)
CH-U18NK2	955	395	700	560	360
CH-U24NK2					
CH-U36NM2	980	425	790	610	395
CH-U48NM2	1120	440	1100	631	400
CH-U60NM2	980	410	1350	572	376

Model	ON/OFF	CH-C18NK2/ CH-U18NK2	CH-C24NK2/ CH-U24NK2	CH-C36NK2/ CH-U36NM2	CH-C48NK2/ CH-U48NM2	CH-C60NK2/ CH-U60NM2
Capacity	Cold/warm	kW		5.00/5.40	7.00/7.60	10.00/11.00
Electric power supply				-220-240V/50Hz/1Ph	-380-415V/50Hz/3Ph	
Rated input	Cold/warm	kW		2.00/1.90	2.50/2.30	3.60/3.30
Current rate	Cold/warm	A		9.20/8.20	11.90/11.40	6.70/5.70
Energy performance	Cold/warm	EER/COP		2.50/2.80	2.80/3.30	2.78/3.55
Air productive capacity		m ³ /h		720/640/580/520	1470/1300/1220/1170	1650/1610/1500/1300
Sound-pressure level	Outdoor unit	dB (A)		50/49/47/46	49/48/47/46	52/47/46/43
	Indoor unit			56	59	60
Type of refrigerant coolant				R410a		
Weight	Indoor unit/ outdoor unit	kg		20/53	27/61	32/60
Volume of refrigerant coolant		Kg		1.30	1.50	2.20
Operational temperature range	Cold/warm	°C		-15 - +43/-15 - +24		
Liquid pipeline diameter		mm/inch		6.35/ 1/4"	9.53/ 3/8"	9.53/ 3/8"
Gas pipeline diameter		mm/inch		12.70/ 1/2"	15.88/ 5/8"	19.05/ 3/4"
Maximum pipeline level difference		m		15		
Pipeline maximum length		m		30		
Distance between the bolt of the outdoor unit fastening		mm		540		
Number of interblock strands (for control)				2*0.75 up to 20 m		
Main power supply area				outdoor		
Number of the strands (power supply)	Indoor unit/ outdoor unit			3(Ø1.0mm)/ 3(Ø4.0mm)	3(Ø1.0mm)/ 3(Ø4.0mm)	3(Ø1.0mm)/ 5(Ø2.5mm)
Factory Freon fill (for the number of the running meters)		r. m.		7		
Freon per one running meter (surplus. for one running meter)		gr. / r. m.		22	54	110

Model	INVERTER	CH-IC12NK4/ CH-IU12NK4	CH-IC18NK4/ CH-IU18NK4	CH-IC24NK4/ CH-IU24NK4	CH-IC36NK4/ CH-IU36NM4	CH-IC42NK4/ CH-IU42NM4	CH-IC48NK4/ CH-IU48NM4	CH-IC60NK4/ CH-IU60NM4
Capacity	Cold	kW		3.5	5.0	7.0	10.0	11.0
	Warm	kW		3.8	5.5	8.0	12.0	12.5
Electric power supply				-220-240V/50Hz/1Ph			-380-415V/50Hz/3Ph	
Rated input	Cold/	kW		1.09	1.6	2.18	3.12	3.9
	Warm	kW		1.05	1.58	2.21	3.32	3.8
Current rate	Cold/	A		5	7.2	10.1	5.4	6.7
	Warm	A		4.9	7.6	10.2	5.8	6.6
Energy performance	Cold	EER		3.21	3.12	3.21	3.2	2.82
	Warm	COP		3.61	3.48	3.61	3.6	3.29
Air productive capacity	indoor unit	m ³ /h		700	760	1300	1860	1860
Sound-pressure level	indoor unit/outdoor unit	dB (A)		46/45/41/36	47/46/44/37	47/46/42/38	51/49/46/43	51/49/46/43
				52	56	57	63	61
Type of refrigerant coolant				R410A				
Refrigerant coolant type		kg		1.2	1.4	2.2	3.5	3.7
Weight	indoor unit/outdoor unit	kg		20/34	20/47	26/67	31/98	31/108
Operational temperature range	Cold	°C		-15/+48				
	Warm	°C		-20/+24				
Liquid pipeline diameter		mm/inch		6.38/ 1/4"	6.38/ 1/4"	9.53/ 3/8"	9.53/ 3/8"	9.53/ 3/8"
Gas pipeline diameter		mm/inch		9.53/ 3/8"	12.70/ 1/2"	15.88/ 5/8"	15.88/ 5/8"	15.88/ 5/8"
Maximum pipeline level difference		m		15				
Pipeline maximum length		m		30				
Number of interblock strands (for control)				2*0.75-up to 20 m			2*1.0-if longer than 20 m	
Main power supply area				outdoor				
Number of the strands (power supply)	indoor unit			3(Ø1.0mm.)	3(Ø1.0mm.)	3(Ø1.0mm.)	3(Ø1.0mm.)	3(Ø1.0mm.)
	outdoor unit			3(Ø1.5mm.)	3(Ø2.5mm.)	3(Ø2.5mm.)	5(Ø1.5mm)	3(Ø2.5mm.)
Factory Freon fill (for the number of the running meters)		r.m.		5				
Freon per one running meter (surplus. per each running meter)		gramm/r.m.		30	30	60	60	60
SEER/SCOP				5.6/4.0	5.6/3.8	6.1/4.0	6.1/4.0	6.1/4.0

* SEER – Seasonal Energy Efficient Rating in the cooling mode. ** SCOP – seasonal system capacity ratio in the heating mode.

FLOOR-CEILING TYPE SERIES

INVERTER



- Compact size;
- Drainage pump (only for inverter models);
- Low noise level;
- Long life washable filter;
- Automatic air distribution in Swing mode
- Self-diagnosis of the main units and modes;
- Multi-level protection system;
- Intelligent defrost;
- Length of the pipe up to 50 m.

Model	CH-IF09NK4/CH-IU09NK4	CH-IF12NK4/CH-IU12NK4	CH-IF18NK4/CH-IU18NK4	CH-IF24NK4/CH-IU24NK4	CH-IF30NK4/CH-IU30NK4
Capacity Cooling/heating kW	2.7/2.9	3.50/3.80	5.00/5.60	7.00/8.00	8.50/9.20
Power Supply	- 220-240V/50Hz/1Ph	- 220-240V/50Hz/1Ph	- 220-240V/50Hz/1Ph	- 220-240V/50Hz/1Ph	- 220-240V/50Hz/1Ph

Model	CH-IF36NK4/CH-IU36NM4	CH-IF42NK4/CH-IU42NM4	CH-IF48NK4/CH-IU48NM4	CH-IF60NK4/CH-IU60NM4
Capacity Cooling/heating kW	10.00/12.00	11.50/13.50	14.00/16.00	16.00/17.00
Power Supply	- 380-415V/50Hz/3Ph	- 380-415V/50Hz/3Ph	- 380-415V/50Hz/3Ph	- 380-415V/50Hz/3Ph

INDOOR UNIT

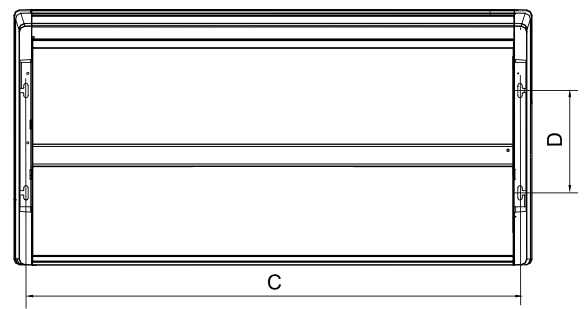
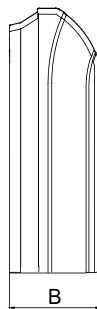
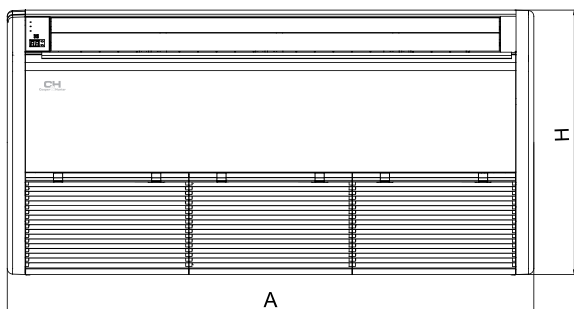

INVERTER

Model	A (mm)	B (mm)	C (mm)	D (mm)	H (mm)
CH-IF09NK4 CH-IF12NK4 CH-IF18NK4 CH-IF24NK4	1220	225	1158	280	700
CH-IF30NK4 CH-IF36NK4 CH-IF42NK4	1420	245	1354	280	700
CH-IF48NK4 CH-IF60NK4	1700	245	1634	280	700

ON/OFF

Model	A (mm)	B (mm)	C (mm)	D (mm)	H (mm)
CH-F18NK2 CH-F24NK2 CH-F36NK2	1200	235	1142	280	665
CH-F48NK2 CH-F60NK2	1570	235	1512	280	665

OUTDOOR UNIT

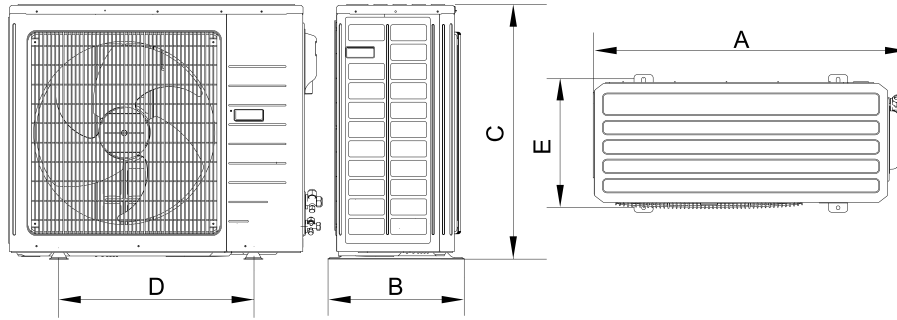

INVERTER

Model	A (mm)	B (mm)	C (mm)	D (mm)	E (mm)
CH-IU09NK4 CH-IU12NK4	848	320	540	540	286
CH-IU18NK4	955	396	700	560	360
CH-IU24NK4 CH-IU30NK4	980	427	790	610	395
CH-IU36NM4	1107	440	1100	631	400
CH-IU42NM4 CH-IU48NM4	958	412	1349	572	376
CH-IU60NM4	1085	427	1365	620	395

ON/OFF

Model	A (mm)	B (mm)	C (mm)	D (mm)	E (mm)
CH-U18NK2 CH-U24NK2	955	395	700	560	360
CH-U36NM2	980	425	790	610	395
CH-U48NM2	1120	440	1100	631	400
CH-U60NM2	980	410	1350	572	376

Model	ON/OFF	CH-F18NK2/ CH-U18NK2	CH-F24NK2/ CH-U24NK2	CH-F36NK2/ CH-U36NM2	CH-F48NK2/ CH-U48NM2	CH-F60NK2/ CH-U60NM2	
Capacity	Cold/warm	kW	5.5/5.7	7.2/8.2	10.6/11.8	14.2/16.0	15.8/18.2
Electric power supply			-220-240V/50Hz/1Ph		-380-415V/50Hz/3Ph		
Rated input	Cold/warm	kW	2.0/1.9	2.5/2.4	3.6/3.6	5.0/4.7	5.50/5.45
Current rate	Cold/warm	A	9.2/8.6	11.4/11.1	8.0/7.5	10.0/10.0	10.7/10.65
Energy performance	Cold/warm	EER/COP	2.7/3.0	2.8/3.4	2.9/3.2	2.8/3.4	2.8/3.3
Air productive capacity		m ³ /h	1000	1400	1600	2400	2400
Sound-pressure level	Outdoor unit	dB (A)	40/37/35/33	48/46/44/40	52/51/50/49	56/55/53/52	56/55/53/52
	Indoor unit		56	59	60	60	61
Type of refrigerant coolant				R410a			
Weight	Indoor unit/ outdoor unit	kg	31/53	32/59	36/90	46/103	46/118
Volume of refrigerant coolant		Kg	1.3	1.5	2.2	3.7	4.1
Operational temperature range	Cold/warm	°C	+15 - +43/-15 - +24				
Liquid pipeline diameter		mm/inch	6.35/ 1/4"	9.53/ 3/8"	9.53/ 3/8"	12.70 / 1/2"	12.70 / 1/2"
Gas pipeline diameter		mm/inch	12.7 / 1/2"	15.88 / 5/8"	19.05 / 3/4"	19.05 / 3/4"	19.05 / 3/4"
Maximum pipeline level difference		m	15				30
Pipeline maximum length		m	25	30	610	631	50
Distance between the bolt of the outdoor unit fastening		mm	560		610	631	672
Number of interblock strands (for control)			2*0.75 up to 20 m		2*1.0 - if longer than 20 m		
Main power supply area			outdoor				
Number of the strands (power supply)	Indoor unit/ outdoor unit		3(∅1.0mm)/ 3(∅4.0mm)	3(∅1.0mm)/ 3(∅4.0mm)	3(∅1.0mm)/ 5(∅2.5mm)	3(∅1.0mm)/ 5(∅4.0mm)	3(∅1.0mm)/ 5(∅4.0mm)
Factory Freon fill (for the number of the running meters)		m.b.	5.0				7.5
Freon per one running meter (surplus per each running meter)		gr/m.b.	15	60	120	120	120

Model	INVERTER	CH-IF09NK4/ CH-IU09NK4	CH-IF12NK4/ CH-IU12NK4	CH-IF18NK4/ CH-IU18NK4	CH-IF24NK4/ CH-IU24NK4	CH-IF30NK4/ CH-IU30NK4	CH-IF36NK4/ CH-IU36NM4	CH-IF42NK4/ CH-IU42NM4	CH-IF48NK4/ CH-IU48NM4	CH-IF60NK4/ CH-IU60NM4	
Capacity	Cold/Warm	kW	2.7/2.9	3.50/3.80	5.00/5.60	7.00/8.00	8.50/9.20	10.00/12.00	11.50/13.50	14.00/16.00	16.00/17.00
Electric power supply			-220-240V/50Hz/1Ph					-380-415V/50Hz/3Ph			
Rated input	Cold/Warm	kW	0.84/0.8	1.09/1.05	1.55/1.55	2.18/2.21	2.67/2.57	3.12/3.32	3.9/3.74	5.2/4.5	5.75/4.7
Current rate	Cold/Warm	A	3.9/3.7	5/4.9	7.2/7.2	10.1/10.2	12.4/12	5.4/5.8	6.7/6.5	8.6/7.8	10.0/10.2
Energy performance	Cold/Warm	EER/COP	3.21/3.61	3.21/3.61	3.23/3.61	3.21/3.62	3.18/3.58	3.21/3.61	3.21/3.61	2.80/3.56	3.78/3.62
Air productive capacity		m ³ /h	600	700	1000	1200	1500	1900	1900	2300	2500
Sound-pressure level	Indoor unit	dB(A)	31/29/26/24	35/33/30/27	44/42/38/32	49/48/46/40	49/46/44/38	54/53/51/46	55/54/52/47	56/52/50/46	58/56/52/46
	Outdoor unit		52	52	56	57	58	63	61	59	63
Type of refrigerant coolant			R410a								
Refrigerant coolant type		kg	1.2	1.2	1.4	2.2	2.4	3.5	3.7	4	5
Weight	Indoor unit/ outdoor unit	kg	38/34	39/34	39/47	40/67	48/71	48/98	50/108	59/114	59/126
Operational temperature range	Cold/Warm	°C	-15/+48/-20/+24					-15/+48/-20/+24			
Liquid pipeline diameter		mm/inch	6.38/ 1/4"	6.38/ 1/4"	6.38/ 1/4"	9.53/ 3/8"	9.53/ 3/8"	9.53/ 3/8"	9.53/ 3/8"	9.53/ 3/8"	9.53/ 3/8"
Gas pipeline diameter		mm/inch	9.53/ 3/8"	9.53/ 3/8"	12.70/ 1/2"	15.88/ 5/8"	15.88/ 5/8"	15.88/ 5/8"	15.88/ 5/8"	15.88/ 5/8"	19.05/ 3/4"
Maximum pipeline level difference		m	15				30	30			
Pipeline maximum length		m	20			30	30		50		
Number of interblock strands (for control)			2*0.75 up to 20 m long			2*1.0 if longer than 20m		2*1.0 - - if longer than 20 m			
Main power supply area			Outdoor unit					Outdoor unit			
Number of the strands (power supply)			3(∅1.0mm)/ 3(∅1.5mm)	3(∅1.0mm)/ 3(∅1.5mm)	3(∅1.0mm)/ 3(∅2.5mm)	3(∅1.0mm)/ 5(∅2.5mm)	3(∅1.0mm)/ 5(∅2.5mm)	3(∅1.0mm)/ 5(∅1.5mm)	3(∅1.0mm)/ 5(∅2.5mm)	3(∅1.0mm)/ 5(∅2.5mm)	3(∅1.0mm)/ 5(∅2.5mm)
Factory Freon fill (for the number of the running meters)		r.m.	5				5		7.5		
Freon per one running meter (surplus per each running meter)		gr/r.m.	30	30	60	60	60	60	60	60	60
SEER/SCOP			6.1/3.8	6.1/4.0	6.1/4.0	5.6/4.0	6.1/4.0	6.1/4.0	5.6/4.0	5.6/4.0	5.1/4.0

* SEER – Seasonal Energy Efficient Rating in the cooling mode. ** SCOP – seasonal system capacity ratio in the heating mode.

MULTY SPLIT AIR CONDITIONING SYSTEM *INVERTER*

NORDIC MULTI LIGHT SERIES



The outdoor units have the production capacity from 14 000 to 42 000 BTU

Model		CHML- U14NK2	CHML- U18NK2	CHML- U21NK3	CHML- U24NK3	CHML- U28NK4	CHML- U36NK4	CHML- U42NK5	
Number of the connected indoor units		1-2	1-2	2-3	2-3	2-4	2-4	2-5	
Capacity	Cold	kW 4.10 (2.10-4.70)	5.00 (2.10-6.21)	6.1 (2.70-8.21)	7.03 (2.20-10.00)	8.00 (2.20-10.00)	9.80 (3.00-10.00)	11.58 (3.50-13.60)	
	Warm	kW 4.40 (2.50-5.51)	5.57 (2.50-6.65)	6.5 (3.50-9.50)	8.50 (3.60-11.00)	9.38 (2.81-11.00)	11.00 (4.50 - 12.00)	13.00 (4.48 - 14.00)	
Electric power supply		- 220-240V/50Hz/1Ph							
Air productive capacity		m ³ /h 2600	3200	3200	4000	4000	5200	5500	
Sound-pressure level		dB (A) 55	56	56	58	58	57	54	
Dimensions (width/depth/height)		mm 899x378x596	955x396x700	955x396x700	980x427x790	980x427x790	1015x440x1103	1015x440x1103	
Weight		kg 43	50	51	68	69	94	102	
Operational temperature		Cold	°C -15/+43				-5/+48		
Operational temperature		Warm	°C -20/+24				-15/+27		
Pipeline maximum length (total for the system/till the one block)		m 20/10	60/20		70/20		80/25		
Maximum pipeline elevation difference (between indoor and outdoor/between indoor)		m 10/5			15/7.5				
Distance between the fastening bolts of the outdoor unit		mm 550	560	560	610	610	631	631	

VIP Inverter



Model			CHML-IW09VNK	CHML-IW12VNK	CHML-IW18VNK
Capacity	Cold / Warm	kW	2.64 / 2.99	3.52 / 3.60	5.27 / 5.27
Air productive capacity		m ³ /h	650	720	850
Sound-pressure level		dB (A)	41/37/35/33/30/22/19	43/38/36/34/31/23/20	46/42/40/36/33/25/22
Dimensions (width/height/depth)		mm	860x305x170	860x305x170	960x320x205
Weight		kg	12.5	12.5	14
Liquid pipeline diameter		mm/inch	6.35 / 1/4"	6.35 / 1/4"	6.35 / 1/4"
Gas pipeline diameter		mm/inch	12.7 / 1/2"	12.7 / 1/2"	12.7 / 1/2"

ALPHA



Model			CHML-IW09AANK with WI-FI	CHML-IW12AANK with WI-FI	CHML-IW18AANK with WI-FI
Capacity	Cold / Warm	kW	2.60 (0.44-3.00) / 2.80 (0.60-3.20)	3.50 (0.60-3.60) / 3.60 (0.60-3.80)	5.00 (0.65-5.20) / 5.30 (0.70-5.28)
Air productive capacity		m ³ /h	210/320/370/480	290/410/480/560	520/610/720/850
Sound-pressure level		dB (A)	23/26/35/38	24/28/37/40	28/33/39/44
Dimensions (width/height/depth)		mm	790x275x200	790x275x200	970x300x224
Weight		kg	9	9	13.5
Liquid pipeline diameter		mm/inch	6.35 / 1/4"	6.35 / 1/4"	6.35 / 1/4"
Gas pipeline diameter		mm/inch	9.52 / 3/8"	9.52 / 3/8"	9.52 / 3/8"

Premium Inverter



Model			CHML-IW07DNK	CHML-IW09DNK	CHML-IW12DNK	CHML-IW18DNK
Capacity	Cold / Warm	kW	2.1 / 2.2	2.64 / 2.87	3.52 / 3.81	5.28 / 5.63
Air productive capacity		m ³ /h	450	450	560	850
Sound-pressure level		dB (A)	25/26/28/30/32/35/37	22/25/27/29/32/34/38	23/25/28/31/34/36/39	28/31/33/35/37/40/44
Dimensions (width/depth/height)		mm	860x153x299	860x153x299	896x159x320	998x178x340
Weight		kg	9.5	9.5	11.5	15
Liquid pipeline diameter		mm/inch	6.35 / 1/4"	6.35 / 1/4"	6.35 / 1/4"	6.35 / 1/4"
Gas pipeline diameter		mm/inch	9.53 / 3/8"	9.53 / 3/8"	9.53 / 3/8"	12.70 / 1/2"

DCInverter



Model			CHML-IW07INK	CHML-IW09INK	CHML-IW12INK	CHML-IW18INK
Capacity	Cold / Warm	kW	2.11 / 2.61	2.61 / 2.81	3.49 / 3.81	5.30 / 5.80
Air productive capacity		m ³ /h	550	600	680	800
Sound-pressure level		dB (A)	-/24/30/38/40	-/24/30/38/41	-/25/31/39/42	-/32/37/40/45
Dimensions (width/depth/height)		mm	770x201x283	770x201x283	770x201x283	865x215x305
Weight		kg	8	8	9	12
Liquid pipeline diameter		mm/inch	6.35 / 1/4"	6.35 / 1/4"	6.35 / 1/4"	6.35 / 1/4"
Gas pipeline diameter		mm/inch	9.53 / 3/8"	9.53 / 3/8"	9.53 / 3/8"	12.70 / 1/2"

Floor-ceiling type units



Model			CHML-IF09NK	CHML-IF12NK	CHML-IF18NK	CHML-IF24NK
Capacity	Cold / Warm	kW	2.50 / 2.80	3.50 / 3.85	5.00 / 5.50	7.10 / 8.00
Air productive capacity		m ³ /h	650	650	950	1250
Sound-pressure level		dB (A)	36/40	36/40	40/45	44/48
Dimensions (width/depth/height)		mm	1220x225x700	1220x225x700	1220x225x700	1220x225x700
Weight		kg	40	40	40	45
Liquid pipeline diameter		mm/inch	6.35 / 1/4"	6.35 / 1/4"	6.35 / 1/4"	9.53 / 3/8"
Gas pipeline diameter		mm/inch	9.53 / 3/8"	9.53 / 3/8"	12.70 / 1/2"	15.88 / 5/8"

Console type units



Model			CHML-IK09NK	CHML-IK12NK	CHML-IK18NK
Capacity	Cold / Warm	kW	2.61 / 2.81	3.49 / 3.81	5.30 / 5.80
Air productive capacity		m ³ /h	480	550	650
Sound-pressure level		dB (A)	24/26/30/33/36/38/40	26/32/35/37/38/40/42	32/35/37/41/44/46/48
Dimensions (width/depth/height)		mm	700x215x600	700x215x600	700x215x600
Weight		kg	15	15	15
Liquid pipeline diameter		mm/inch	6.35 / 1/4"	6.35 / 1/4"	6.35 / 1/4"
Gas pipeline diameter		mm/inch	9.53 / 3/8"	9.53 / 3/8"	12.70 / 1/2"

Cassette type units



Model			CHML-IC12NK	CHML-IC18NK	CHML-IC24NK
Capacity	Cold / Warm	kW	3.50 / 4.00	4.50 / 5.00	7.10 / 8.00
Air productive capacity		m ³ /h	600	600	1180
Sound-pressure level		dB (A)	41/47	41/47	35/39
Dimensions (width/depth/height)	indoor unit	mm	570x570x230	570x570x230	840x840x240
	panel	mm	650x650x50	650x650x50	950x950x60
Weight (cassette/panel)		kg	18/2.5	18/2.5	30/6.5
Liquid pipeline diameter		mm/inch	6.35 / 1/4"	6.35 / 1/4"	9.53 / 3/8"
Gas pipeline diameter		mm/inch	9.53 / 3/8"	12.70 / 1/2"	15.88 / 5/8"

Duct type units



Model			CHML-ID09NK	CHML-ID12NK	CHML-ID18NK	CHML-ID21NK	CHML-ID24NK
Capacity	Cold / Warm	kW	2.50 / 2.80	3.50 / 3.85	5.00 / 5.50	6.00 / 6.60	7.10 / 8.00
Air productive capacity		m ³ /h	450	500	700	1000	1000
Sound-pressure level		dB (A)	31/37	32/39	33/41	34/42	34/42
Dimensions (width/depth/height)		mm	700x615x200	700x615x200	900x615x200	1100x615x200	1100x615x200
Weight		kg	22	23	27	31	31
Liquid pipeline diameter		mm/inch	6.35 / 1/4"	6.35 / 1/4"	6.35 / 1/4"	9.53 / 3/8"	9.53 / 3/8"
Gas pipeline diameter		mm/inch	9.53 / 3/8"	9.53 / 3/8"	12.70 / 1/2"	15.88 / 5/8"	15.88 / 5/8"

INDOOR UNITS LINEUP

BTU	7 000	9 000	12 000	18 000	21 000	24 000
Wall-mounted Indoor Unit						
Floor-Ceiling Type Indoor Unit						
Console Indoor Unit						
Cassette Indoor Unit						
Duct Type Indoor Unit						

COMBINATIONS OF OUTDOOR UNITS

8 combinations

 CHML-U14NK2(1to2)	One unit	Two units	
	7	7+7	7+9
	9	7+12	9+9
	12	9+12	

10 combinations

 CHML-U18NK2(1to2)	One unit	Two units		
	7	7+7	7+18	12+12
	9	7+9	9+9	
	12	7+12	9+12	

18 combinations

 CHML-U21NK3(2to3)	Two units		Three units	
	7+7	7+9	7+7+7	7+7+9
	7+12	7+18	7+7+12	7+9+9
	9+9	9+12	7+9+12	7+12+12
	9+18	12+12	9+9+9	9+9+12
	12+18		12+12+12	

23 combinations

 CHML-U24NK3(2to3)	Two units		Three units		
	7+7	7+9	7+7+7	7+7+9	7+7+12
	7+12	7+18	7+7+18	7+9+9	7+9+12
	9+9	9+12	7+9+18	7+12+12	9+9+9
	9+18	12+12	9+9+12	9+9+18	9+12+12
	12+18	18+18	12+12+12		

40 combinations

 CHML-U28NK4(2to4)	Two units		Three units			Four units		
	7+7	7+9	7+7+7	7+7+9	7+7+12	7+7+7+7	7+7+7+9	7+7+7+12
	7+12	7+18	7+7+18	7+9+9	7+9+12	7+7+7+18	7+7+9+9	7+7+9+12
	9+9	9+12	7+9+18	7+12+12	7+12+18	7+7+9+18	7+7+12+12	7+9+9+9
	9+18	12+12	9+9+9	9+9+12	9+9+18	7+9+9+12	7+9+12+12	9+9+9+9
	12+18	18+18	9+12+12	9+12+18	12+12+12	9+9+9+12	9+9+12+12	
		12+12+18						

97 combinations

 CHML-U36NK4(2to4)	Two units		Three units			Four units		
	7+12	7+18	7+7+7	7+7+9	7+7+12	7+7+7+7	7+7+7+9	7+7+7+12
	7+21	7+24	7+7+18	7+7+21	7+7+24	7+7+7+18	7+7+7+21	7+7+7+24
	9+9	9+12	7+9+9	7+9+12	7+9+18	7+7+9+9	7+7+9+12	7+7+9+18
	9+18	9+21	7+9+21	7+9+24	7+12+12	7+7+9+21	7+7+9+24	7+7+12+12
	9+24	12+12	7+12+18	7+12+21	7+12+24	7+7+12+18	7+7+12+21	7+7+18+18
	12+18	12+21	7+18+18	7+18+21	7+18+24	7+9+9+9	7+9+9+12	7+7+12+24
	12+24	18+18	7+21+21	9+9+9	9+9+12	7+9+9+21	7+9+9+24	7+9+9+18
	18+21	18+24	9+9+18	9+9+21	9+9+24	7+9+12+18	7+9+12+21	7+9+12+12
	21+21	21+24	9+12+12	9+12+18	9+12+21	7+12+12+12	7+12+12+18	7+9+18+18
	24+24		9+12+24	9+18+18	9+18+21	9+9+9+12	9+9+9+18	9+9+9+9
			9+18+24	9+21+21	12+12+12	9+9+9+24	9+9+12+12	9+9+9+21
			12+12+18	12+12+21	12+12+24	9+9+12+21	9+9+18+18	9+9+12+18
			12+18+18	12+18+21	18+18+18	9+12+12+18	12+12+12+12	9+12+12+12

171 combinations

 CHML-U42NK5(2to5)	Two units		Three units			Four units				Five units			
	7+18	7+21	7+7+7	7+7+9	7+7+12	7+7+7+7	7+7+7+9	7+7+7+12	7+7+7+18	7+7+7+7+7	7+7+7+7+9	7+7+7+7+12	7+7+7+7+18
	7+24	9+12	7+7+18	7+7+21	7+7+24	7+7+7+21	7+7+7+24	7+7+9+9	7+7+9+12	7+7+7+7+21	7+7+7+7+24	7+7+7+9+9	7+7+7+9+12
	9+18	9+21	7+9+9	7+9+12	7+9+18	7+7+9+18	7+7+9+21	7+7+9+24	7+7+12+12	7+7+7+9+18	7+7+7+9+21	7+7+7+9+24	7+7+7+12+12
	9+24	12+12	7+9+21	7+9+24	7+12+12	7+7+12+18	7+7+12+21	7+7+12+24	7+7+18+18	7+7+7+12+18	7+7+7+12+21	7+7+9+9+12	7+9+9+9+9
	12+18	12+21	7+12+18	7+12+21	7+12+24	7+7+18+21	7+7+18+24	7+7+21+21	7+7+21+24	7+7+7+18+21	7+7+9+9+9	7+7+9+12+12	7+7+9+9+18
	12+24	18+18	7+18+18	7+18+21	7+18+24	7+9+9+9	7+9+9+12	7+9+9+18	7+9+9+21	7+7+9+9+21	7+9+9+9+18	7+9+9+9+21	7+7+9+12+18
	18+21	18+24	7+21+21	7+21+24	7+24+24	7+9+9+24	7+9+12+12	7+9+12+18	7+9+12+21	7+7+9+12+21	7+9+9+12+18	7+9+12+12+18	7+7+12+12+12
	21+21	21+24	9+9+9	9+9+12	9+9+18	7+9+12+24	7+9+18+18	7+9+18+21	7+9+18+24	7+7+12+12+18	7+9+12+12+12	9+9+9+9+9	7+9+9+9+24
	24+24		9+9+21	9+9+24	9+12+12	7+9+21+21	7+9+21+24	7+12+12+12	7+12+12+18	7+12+12+18	7+9+9+9+12		7+9+12+12+21
			9+12+18	9+12+21	9+12+24	7+12+12+21	7+12+12+24	7+12+18+18	7+12+18+21	7+9+9+12+12			9+9+9+9+12
			9+18+18	9+18+21	9+18+24	7+12+18+24	7+12+21+21	7+18+18+18	9+9+9+9	7+9+9+18+18			9+9+9+12+12
			9+21+21	9+21+24	9+24+24	9+9+9+12	9+9+9+18	9+9+9+21	9+9+9+24	7+12+12+12+12			9+9+12+12+12
			12+12+12	12+12+18	12+12+21	9+9+12+12	9+9+12+18	9+9+12+21	9+9+12+24	9+9+9+9+18			
			12+12+24	12+18+18	12+18+21	9+9+18+18	9+9+18+21	9+12+12+21					
			12+18+24	12+21+21	12+21+24	9+12+12+12	9+12+12+18						
			12+24+24	18+18+18	18+18+21	9+12+18+18	9+12+18+21						
		18+18+24	18+21+21		12+12+12+12	12+12+12+18							
					12+12+18+18	12+12+18+21							

BIG DUCT SPLIT UNIT



INVERTER



- All DC inverter for high efficiency and energy saving.
- High static units for longer ducted runs.
- ESP reach up to 250Pa high.
- Static pressure is adjustable.
- Long-distance control is optional, with intelligent filter cleaning reminding function.
- Indoor fan can be adjusted according to the static pressure of air duct installed by customers.

Model	Heat pump		CH-IBD20NM	CH-IBD25NM	CH-IBD30NM	CH-IBD40N (2) M *
Capacity	Cooling	kW	20	25	30	40
		BTU/h	68200	85303	102364	136486
	Heating	kW	23	28	34	43
		BTU/h	78479	95540	116013	146722

*: If the capacity of outdoor units is 40 kW, Two outdoor units are needed for the operation of one indoor unit

INDOOR UNIT

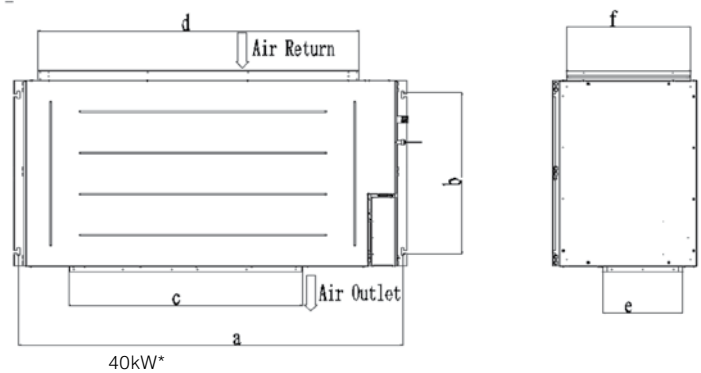
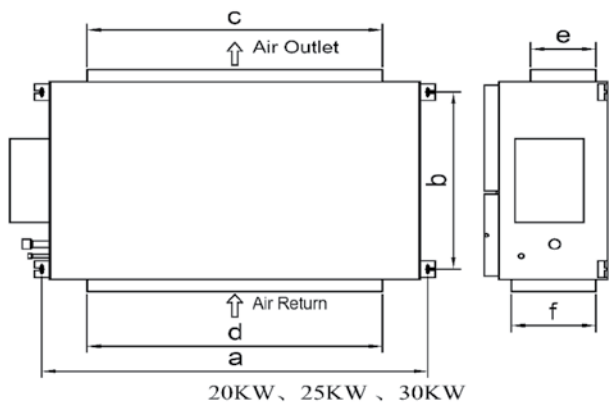

Model	A (mm)	B (mm)	C (mm)	D (mm)	E (mm)	F (mm)
CH-IBD20NM(I)	1334	632	990	1150	192	363
CH-IBD25NM(I)	1541	705	980	1350	270	420
CH-IBD30NM(I)	1541	705	980	1350	270	420
CH-IBD40N(2)M(I)	1730	760	1054	1450	360	560

OUTDOOR UNIT

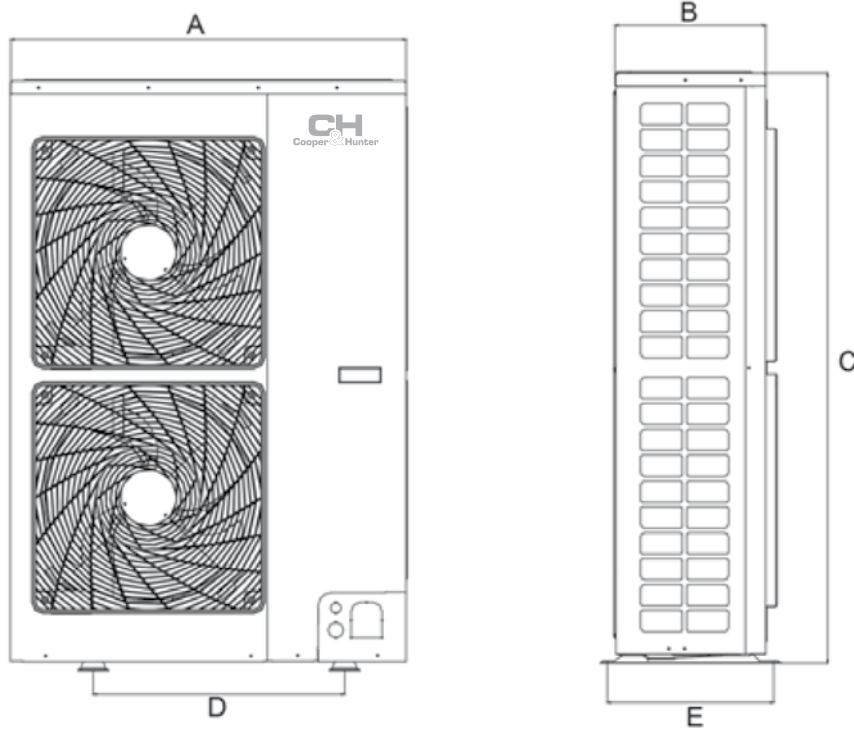

Model	A (mm)	B (mm)	C (mm)	D (mm)	E (mm)
CH-IBD20NM(O)	940	320	1430	632	350
CH-IBD25NM(O)	940	460	1615	610	486
CH-IBD30NM(O)	940	460	1615	610	486

Model	Heat pump		CH-IBD20NM	CH-IBD25NM	CH-IBD30NM	CH-IBD40N (2) M	
Capacity	Cooling	kW	20	25	30	40	
		BTU/h	68200	85303	102364	136486	
	Heating	kW	23	28	34	43	
		BTU/h	78479	95540	116013	146722	
EER/COP		W/W	2.70/3.15	2.70/3.15	2.70/3.15	2.70/3.15	
Power supply		Ph/V/Hz	-380-415V/50Hz/3Ph				
Power input	Cooling	kW	7.4	9.3	11.1	14.8	
	Heating	kW	7.3	8.9	10.8	13.7	
Current input	Cooling	A	14.5	18.2	21.7	29	
	Heating	A	14.3	17.4	21.2	26.8	
Refrigerant charge volume		kg	5.5	7.1	9.5	11	
Type of refrigerant coolant			R410a				
Indoor unit	Air flow volume		CFM	2236	2590	3178	4120
			m³/h	3800	4400	5400	7000
	ESP	Rated	Pa	120	120	120	120
		Range	Pa	0-250	0-250	0-250	0-250
	Sound pressure level		dB (A)	53	54	55	56
Net weight/Gross weight		Kg	82/104	99/134	105/140	175/210	
Outdoor unit	Sound pressure level		dB (A)	62	64	65	66
	Net weight/Gross weight		kg	115/126	146/162	165/182	230/252
	Outer diameter	Liquid	inch (mm)	3/8" (9.52)	3/8" (9.52)	1/2" (12.7)	3/8" (9.52)
Gas		inch (mm)	3/4" (19.05)	7/8" (22)	1" (25.4)	3/4" (19.05)	
Max. distance	Height	m	40	40	40	40	
	Length	m	70	70	70	70	
Loading quantity	20' GP		set	28	22	22	14
	40' GP/40' HQ		set	56/56	44/44	44/44	28/28

Item	Nominal operating condition (temperature)				Operating range (temperature)
	Outdoor condition		Indoor condition		Outdoor condition
	DB (°C)	WB (°C)	DB (°C)	WB (°C)	DB (°C)
Cooling	35	24	27	19	-15-48
Heating	7	6	20	15	-15-24

Heat Pumps For Heating And Hot Water Supply



FUNCTIONS AND ADVANTAGES

- Heating of the room; Cooling of the room;
- Water heating for hot water supply;
- Room cooling and water heating;
- Weather-dependet mode
- Automatic climate control;
- Emergency water heating mode;
- Quick water heating;
- Noiseless (night) mode;
- Anti-frizzing mode;
- Sanitary mode (heating of water in the boiler to 80°C); Programming unit for 7 days;
- Central control;

OUTDOOR UNIT

- DC-inverter two-stage compressor of a new generation (UNITERM 3);
- DC inverter double-rotor compressor of a new generator (UNITERM 2);
- High class of energy efficiency A: COP 4,5;
- Safe start and operation within the range from 95V to 260V;
- Wide temperature range of effective operation:
 - from -30°C when heating and up to +48°C when cooling (UNITERM 3);
 - from -25°C when heating and up to +48°C when cooling (UNITERM 2);
- Compressor starts with low inrush current (up to 5A);
- Multi-level protection system;
- Energy saving mode;

INDOOR UNIT

- Gorgeous design and compact size (900x500x324 mm);
 - Plate type heat exchanger with the maximum energy efficiency ratio C.O.P;
 - Reliable inverter pump;
 - Intelligent control system;
- ### BOILER* (200L, 300L)
- Is installed into the hot water supply system;
 - Boiler and heat exchanger are made of stainless steel;
 - Magnesium anod (effective scale protection);
 - Two temperature sensors;
 - Easy use and maintenance.

*Additional paid option.

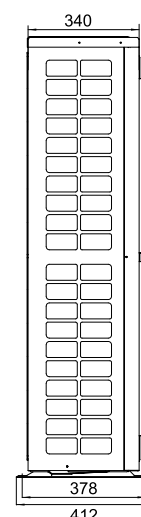
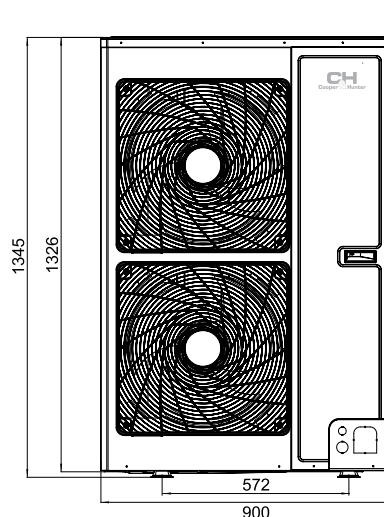
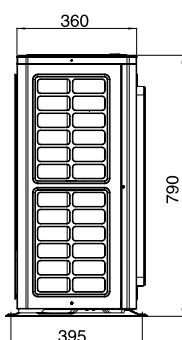
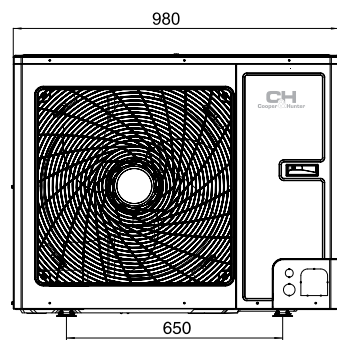
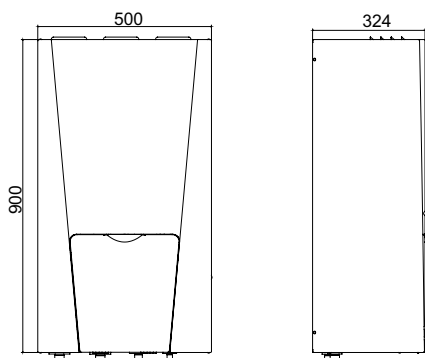

-25°C

UNITHERM2 SERIES

Model			CH-HP8.0SINK2	CH-HP10SINK2	CH-HP12SINK(M)2	CH-HP14SINK(M)2	CH-HP16SINK(M)2
Capacity*	Cold	kW	7.8	8.2	12.5(13.5)	13.5(14.5)	14.5(15)
	Warm	kW	8	10	12(12)	14(14)	15.5(15.5)
Rated Input*	Cold	kW	1.95	2.1	3(3.55)	3.4(3.95)	3.8(4.2)
	Warm	kW	1.778	2.273	2.8(2.8)	3.3(3.35)	3.75(3.85)
Energy performance	Cold	EER	3.9	4.0	4.2(3.8)	4(3.7)	3.8(3.6)
	Warm	COP	4.4	4.5	4.3(4.3)	4.2(4.2)	4.1(4.05)
Capacity** (for fan coil unit or radiator)	Cold	kW	6.3	7.2	8.5(10)	9(10.5)	9.5(11)
	Warm	kW	7.6	9.5	11.5(12)	12.5(13.5)	14.5(14)
Rated Input** (for fan coil unit or radiator)	Cold	kW	2.33	2.77	2.7(3.35)	3(3.6)	3.3(3.8)
	Warm	kW	2.24	2.88	3.4(3.55)	3.8(4.05)	4.5(4.25)
Energy performance (for fan coil unit or radiator)	Cold	EER	2.6	2.7	3.1(3)	3(2.95)	2.9(2.9)
	Warm	COP	3.3	3.4	3.35(3.4)	3.3(3.35)	3.2(3.3)
Weight of refrigerant coolant		kg		2.3		3.6	
Sound Pressure Level	Outdoor Unit	Cold	dB (A)		54		56(55)
		Warm	dB (A)		56		58(57)
	Indoor Unit	Cold	dB (A)		31		
		Warm	dB (A)		31		
Dimensions (WxDxH)	Outdoor Unit	mm	980x427x788		900x412x1345		
	Indoor Unit	mm			981x324x500		
Net weight/Gross weight	Outdoor Unit	kg	80/85		107(114)/117(124)		
	Indoor Unit	kg	56/65		57(58)/66(67)		
Sanitary water Temperature		°C			40-80		
Operational temperature range	Heating	°C			-25 -- +35		
Operational temperature range	Cooling	°C			+10 -- +48		
Liquid pipeline diameter					3/8" (9,52 mm)		
Gas pipeline diameter					5/8" (15,9 mm)		
Maximum pipeline level difference		m			15		
Pipeline maximum length		m			30		

*the meanings in brackets are for the models operating from the power supply -380-415V/50 Hz/3Ph and marked (M)

-30°C

UNITHERM3 SERIES

UNITHERM3 split unit is designed specially for the European market. The whole series of products strictly comply with EN14511-2100 and EVROVENT energy efficiency class A.

Model			CH-HP8.0SINK3	CH-HP10SINK3	CH-HP12SINK3	CH-HP14SINK3
Capacity*	Cold	kW	8.2	9.7	13.5	14
	Warm	kW	8	9.2	12	14
Power supply	W/Hz/Ph		- 220-240V/50Hz/1Ph		- 380-415V/50Hz/3Ph	
Rated input *	Cold	kW	1.86	2.46	3.46	3.68
	Warm	kW	1.85	2.19	2.67	3.33
Energy performance	Cold	EER	4.41	3.94	3.90	3.80
	Warm	COP	4.32	4.20	4.49	4.20
Capacity**(for fan coil unit or radiator)	Cold	kW	5.5	6.9	9.6	10
	Warm	kW	7.7	9	12	12.8
Rated input **(for fan coil unit or radiator)	Cold	kW	1.85	2.34	3.02	3.22
	Warm	kW	2.26	2.65	3.24	3.56
Energy performance**(for fan coil unit or radiator)	Cold	EER	2.97	2.95	3.18	3.11
	Warm	COP	3.41	3.40	3.70	3.60
Weight of refrigerant coolant		kg	5.3	5.3	5.3	5.3
Sound-pressure level	indoor unit	dB (A)			31	
	outdoor unit	dB (A)	53	53	57	57
Dimensions (WxDxH)	indoor unit	mm			981x324x500	
	outdoor unit	mm	980x427x788		900x412x1345	
Net Weight/Gross Weight	indoor unit	kg	56/65		58/67	
	outdoor unit	kg	85/87		126/136	
Sanitary water Temperature		°C			40-80	
Operational temperature range	Heating	°C			-30°C -- +45°C	
Operational temperature range	Cooling	°C			-10°C -- +48°C	
Liquid pipeline diameter					3/8" (9,52 mm)	
Gas pipeline diameter					5/8" (15,9 mm)	
Maximum pipeline level difference		m			15	
Pipeline maximum length		m			30	

*indicates the capacity and power input are tested based on the conditions below: Cooling. Indoor Water Temperature: 23°C/18°C, Outdoor Temperature: 35°CDB/24°CWB; Heating. Indoor Water Temperature: 30°C/35°C, Outdoor Temperature: 7°CDB/6°CWB

** indicates the capacity and power input are tested based on the conditions below: Cooling. Indoor Water Temperature: 12°C/7°C, Outdoor Temperature: 35°CDB/24°CWB; Heating. Indoor Water Temperature: 40°C/45°C, Outdoor Temperature: 7°CDB/6°CWB

Household Heat Air-water pump with HWS boiler



Two-stage
Compressor



- Two-stage compressor;
- Operation range of outdoor temperature: from -25 to +45°C;
- Range of incoming temperatures of the sanitary water is from +35°C to +70°C;
- Multi-speed ventilator;
- Modular multi-stage water apparatus for HWS Systems on freon R410A; Build-in heating element for 1500 W (to compensate losses of useful heat when the outdoor temperature goes down);
- Basic configuration "installed and forgot": outdoor unit, GAM boiler, wire-connected controller;



INVERTER



Outdoor unit model		CH-HP3.5SWNK
Rated heat power	W	3500
Rated power consumption	W	850

WATER TANK

Model		WT200SW1.5EHK
Volume	l	185
Power supply parameters of the heating element	W	- 220-240V/50Hz/1Ph
Heating element power intake	W	1500
Dimension (WxDxH)	mm	545 x 545 x 1919
Diameters of connected freon pipelines	mm	Ø6.38/Ø9.52

OUTDOOR UNIT

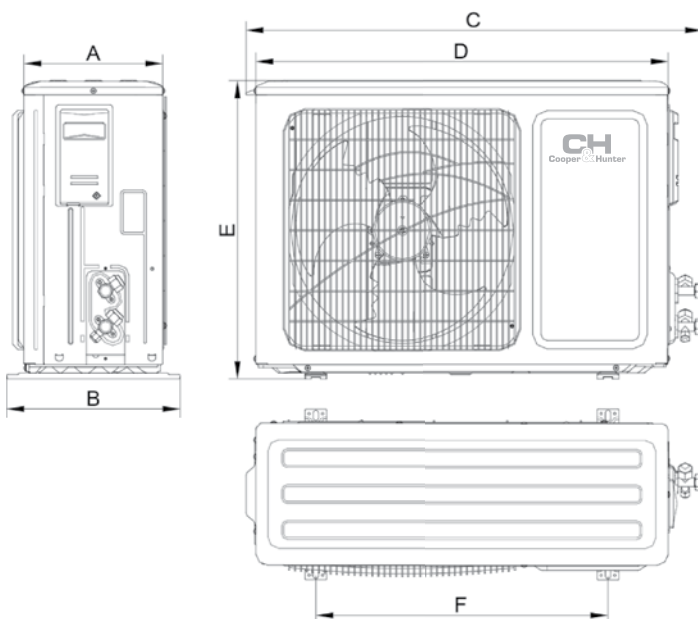

Model		CH-HP3.5SWHK
Normal heat release	W	3500
Rated input	W	850
Load type	A	L
COP		3.17
Energy efficiency ratio		A
Maximum Power intake	W	1500+1500W (EHT)
Output water temperature	°C	Standard: 55°C. 35°C-55°C
Power supply parameters		- 220-240V/50Hz/1Ph
Isolation class		I
Protection class		IPX4
Type of refrigerant coolant		R410A
Fill of refrigerant coolant	kg	1.40
Sound-pressure level	dB (A)	63
Operational range of outdoor temperatures	°C	-25-+45

Model	A (mm)	B (mm)	C (mm)	D (mm)	E (mm)	F (mm)
CH-HP3.5SWHK	260	320	842	784	591	540

Industrial pump for heating and HWS systems



ON/OFF



30 KW, 40 KW



60 KW

- Simple installation;
- Compact size;
- Wide operational temperature range -26°C +46°C;
- Quick water heating;
- Reliable and highly efficient compressor DANFOSS with high COP ratio;
- Anti-corrosion coating of the heat exchanger;
- Low noise level;
- Possibility to install up to 16 units in one system, up to 0,96 MW;
- Group control.

Model		CH-HP30MFNM	CH-HP40MFNM	CH-HP60MFNM
Heating capacity	kW	31	40	60
Power intake	kW	8.1	10	15
Consumed current	A	14.5	19	28
COP		3.8	4	4
Standard hot water supply	l/h	667	860	1300
Specified range of hot water temperature	°C	35-70		
Electric power supply		- 380-415V/50Hz/3Ph		
Automatic switch off	A	25	32	40
Electric power supply cable	mm	5*4.0	5*4.0	5*6.0
Type of refrigerant coolant		R-410A		
Volume of refrigerant coolant	kg	3.9	4.73	6.5
Compressor type		scroll		
Quantity of compressor	piece	1	1	1
Operational temperature range	°C	from -26 to +46	from -26 to +46	from -26 to +46
Diameters of connected water pipelines	Outdoor water supply	DN 25	DN 25	DN 32
	Recirculating inlet water	DN 32	DN 32	DN 50
	Output water	DN 32	DN 32	DN 50
Dimensions (WxDxH)	mm	930x800x1605	930x800x1605	1340x800x1605
Sound-pressure level	dB (A)	67	67	67
Netto/Brutto	kg	238/252	264/286	362/378

MULTIPOWER



ON/OFF



Multifunctional heat generators with liquid injection scroll compressor for the production of hot water up to 65°C.

Model	CH-MP272NM	CH-MP315NM	CH-MP358NM	CH-MP411NM	CH-MP462NM	CH-MP501NM
Capacity Cooling/heating kW	23.7/27.2	29.4/31.5	32.2/35.8	36.4/41.1	41.2/46.2	44.5/50.1
Power Supply	- 380-415V/50Hz/3Ph					

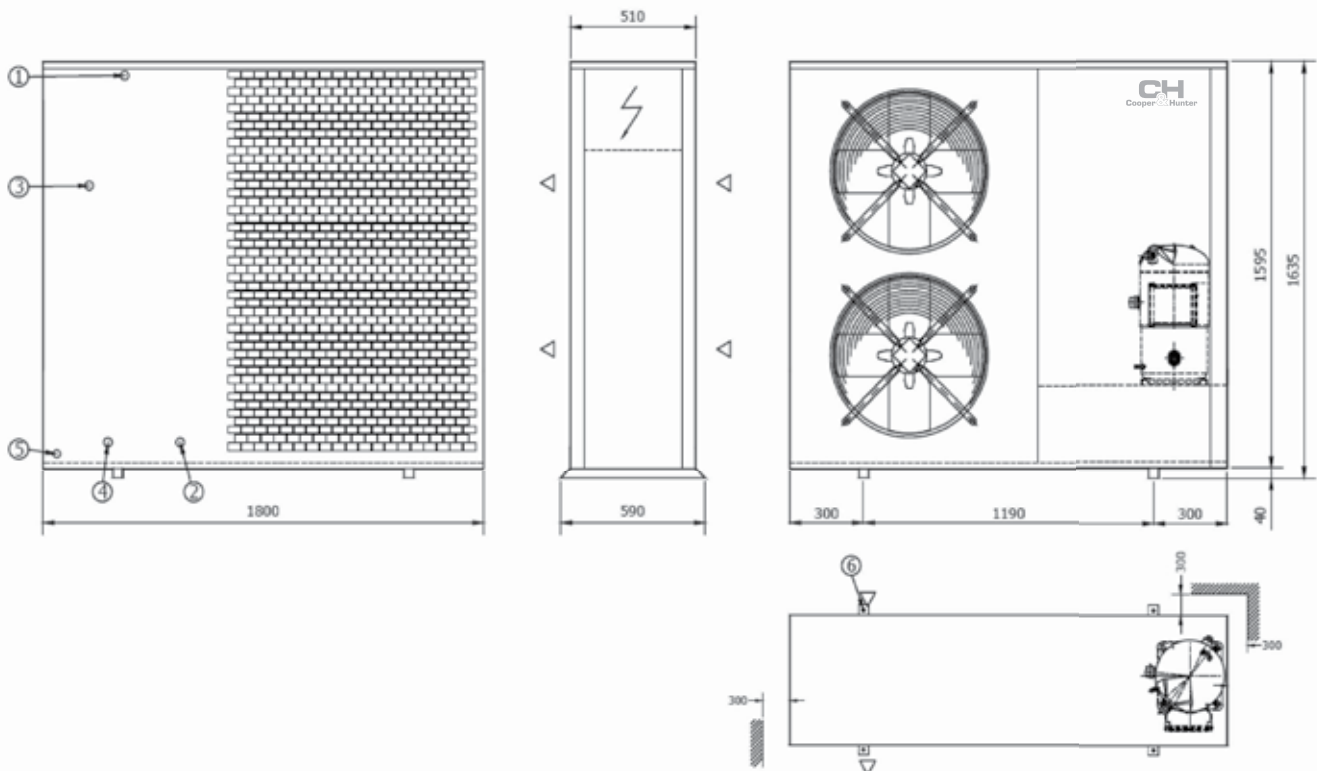

Model	CH-MP272NM	CH-MP315NM	CH-MP358NM	CH-MP411NM	CH-MP462NM	CH-MP501NM	
Cooling/Heating capacity	kW	23.7/27.2	29.4/31.5	32.2/35.8	36.4/41.1	41.2/46.2	44.5/50.1
Power input (Warm/Cold)	kW	8.04/7.24	9.3/9.2	10.5/10.2	12.2/11.5	13.7/13.3	14.9/14.6
COP/EER		3.38/3.27	3.39/3.20	3.41/3.16	3.37/3.17	3.37/3.10	3.36/3.05
Specified range of hot water temperature	°C	up to 65					
Electric power supply		- 380-415V/50Hz/3Ph					
Type of refrigerant coolant		R410A					
Operational temperature range	°C	from -20 to +45					
Dimensions (HxDxW)	mm	1635x590x1300	1635x590x1800	1635x590x1800	1635x590x1800	1635x590x1800	1635x590x1800
Sound-pressure level	dB (A)	72	74	74	74	74	74
Weight	kg	202	295	361	369	386	395

- Scroll compressor optimized for heat pump with innovative liquid injection system.
- Fans propeller type.
- Water side evaporator stainless steel AISI 316 brazed plate type externally insulated complete of differential pressure switch and antifreeze protection electric heater.
- Hot sanitary water evaporator stainless steel AISI 316 brazed plate type externally insulated complete of differential pressure switch and antifreeze protection electric heater.
- Condenser coils with seamless copper tubes and alluminium fins.
- Double set point temperature for comfort cooling/heating water and for sanitary water.
- Anti-legionella measures.
- Condensing and evaporating pressure control with variable fan speed modulation for external temperature up to -20°C .
- Hot sanitary water circuit equipped with variable flow rate circulators.
- Air conditioning circuit equipped with variable flow rate circulators.
- Microprocessor.
- Galvanised steel base frame and panels in powder painted galvanised steel sheet for outdoor installation.
- Communication card RS485.

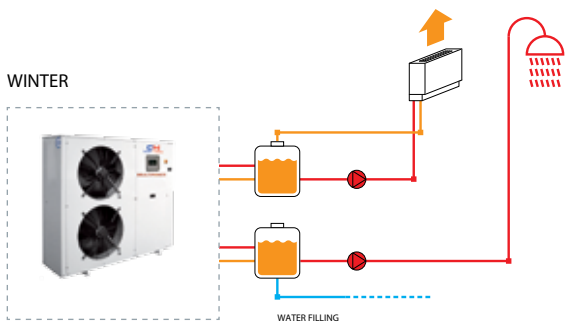

WINTER AIR-CONDITIONING AND HOT SANITARY WATER PRODUCTION

Production of hot water (up to 65°C) for the heating and hot water production (giving priority to the sanitary consumptions).

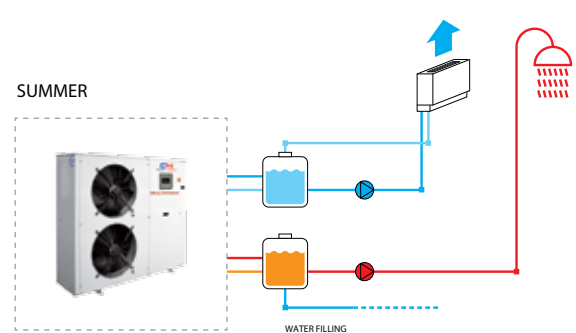

SUMMER AIR-CONDITIONING AND HOT WATER PRODUCTION

Production of cold water for the cooling and free of costs hot water production (up to 65°C) to serve sanitary consumptions.



FLOOR-CEILING TYPE FAN COIL UNIT



- Finned coil type heat-exchanger consisting of copper tubes and aluminum fins, with connections on the left reversible to fit on the right.
- Three-speed centrifugal blower with aluminum blades statically and dynamically balanced.
- Directly-coupled motor equipped with internal thermal protection and condenser permanently in circuit.
- Casing in pre-painted galvanized steel sheet, clad in a protective film of PVC, complete with the acoustic insulation, grilles in heat-resistant ABS polymer with fixed vanes.
- Condensation collection tray with natural drainage, complete with anti-condensation insulation.
- Mesh filter in regenerable polypropylene.

Model	CH-FFC015K2	CH-FFC020K2	CH-FFC025K2	CH-FFC035K2	CH-FFC040K2	CH-FFC050K2	CH-FFC060K2	CH-FFC065K2	CH-FFC090K2
Cooling capacity (W)	1150	1870	2530	3270	3970	4850	5640	6520	7850
Heating capacity (W)	1520	2530	3490	4580	5640	6980	8230	9580	11690
Air volume (m ³ /h)	255	425	510	680	765	850	1020	1360	1530
Sound pressure (dB (A))	32	35	37	39	41	43	44	46	48
Rated input (W)	29	30	44	44	36	51	64	95	143
Weight (kg)	22.5	22.5	26	26	32.5	32.5	39	39	39
Power supply	~ 220-240V/50Hz/1Ph								

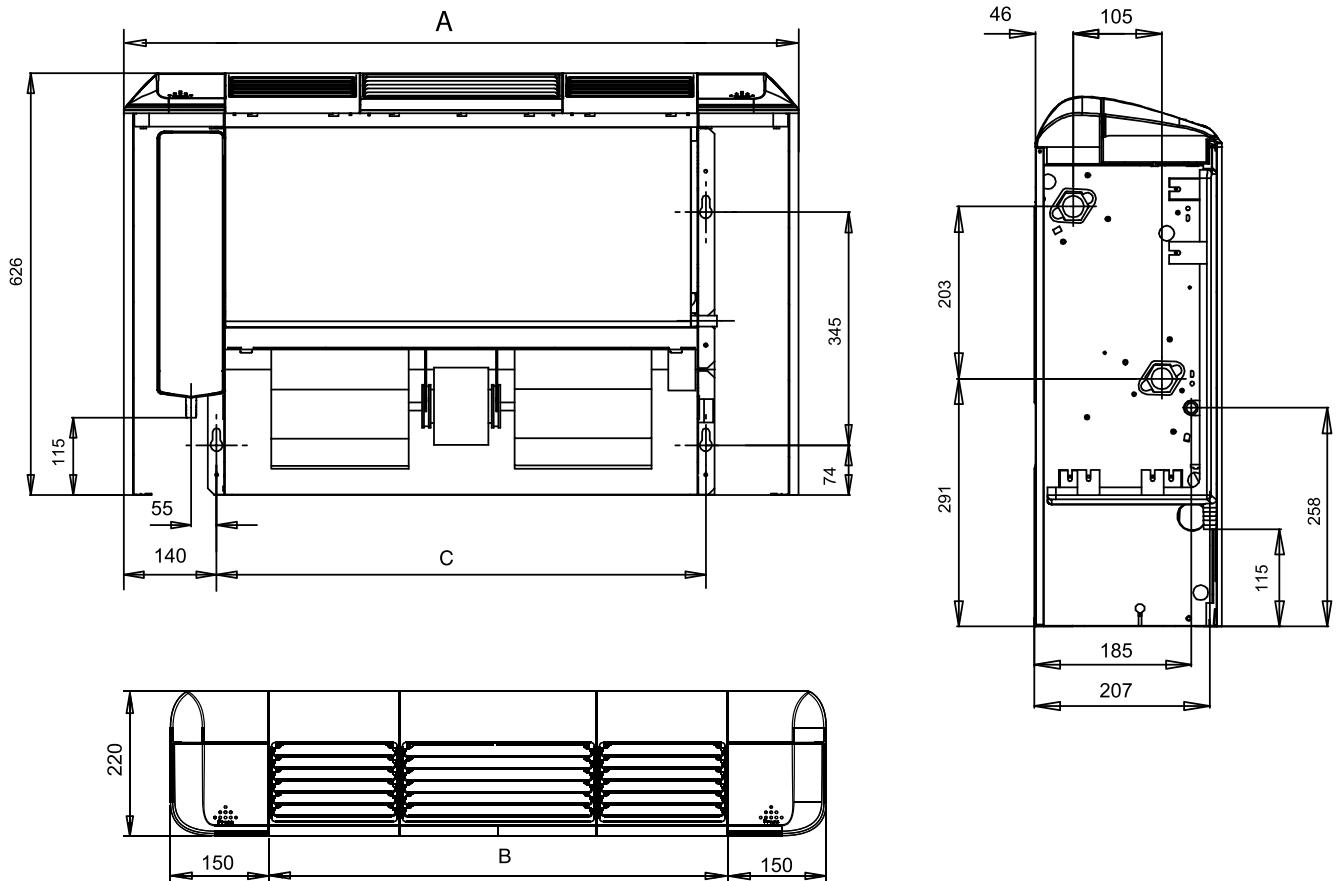

Model	CH-FFC015K2	CH-FFC020K2	CH-FFC025K2	CH-FFC035K2	CH-FFC040K2	CH-FFC050K2	CH-FFC060K2	CH-FFC065K2	CH-FFC090K2
A (mm)	800	800	1000	1000	1200	1200	1500	1500	1500
B (mm)	500	500	700	700	900	900	1200	1200	1200
C (mm)	526	526	726	726	926	926	1226	1226	1226

WIRED CONTROLLER KJR-18B/E



- KJR-18B/E is a thermostat that has developed into 2 types. Each type has its own features to suit different environment.

Model	Features
KJR-18B/E-A	Only control 3-speed fan, when the temperature reaches the set-point, it will close the Fan
KJR-18B/E-B	Control motorized valve and 3-speed fan, when the temperature reaches the set-point, it will close the motorized valve and fan both

DUCT TYPE 2-ROWS FAN COIL UNIT

- Left or right hand piping connection, field convertible.
- Quiet operation.
- A patent design is able to prevent abnormal noise caused by blowing fins.
- Superior air distribution.
- As the conditioner air can be distributed to every corner of the area by air duct, this will ensure more pleasant living environment, thus provide extra comfort to the occupants.
- Fresh air supply makes life healthier and more comfortable.
- Air return plenum.
- Units with air return plenum is standard and units without air return plenum can be customized.
- Washable filter.



- Iron frame filter is standard, and aluminum frame filter can be customized.
- Air outlet flange and multi-direction pull-out filter can be customized.
- Optional wired controller.
- Optional wired controller offers simple and flexibility in controlling the unit.

Model		CH-FDH 020K2	CH-FDH 030K2	CH-FDH 035K2	CH-FDH 045K2	CH-FDH 060K2	CH-FDH 075K2	CH-FDH 100K2	CH-FDH 110K2	CH-FDH 120K2
Cooling capacity (W)	H	2000	2700	3600	4400	5500	7500	8900	10800	12300
	M	1740	2310	3110	3740	4580	6330	7610	9130	10460
	L	1520	2030	2660	3250	4090	5680	6410	7930	9270
Heating capacity (W)	H	3200	4300	5400	6800	8100	11000	13500	16500	19500
	M	2750	3740	4640	5780	6770	9480	11720	14050	16850
	L	2370	3230	4050	5070	5920	8250	10030	12240	14630
Air flow (m ³ /h)	H	340	510	680	850	1020	1360	1700	2040	2380
	M	255	385	510	640	765	1020	1275	1530	1785
	L	170	255	340	425	510	680	850	1020	1190
Sound pressure (dB (A))	H	41	41	42	45	46	46	47	48	49
	M	37	37	39	41	41	41	43	44	44
	L	31	32	33	34	35	36	37	38	39
Rated input (W)		45	60	67	89	110	130	171	212	249
Weight (kg)		16	18.5	20	20	24	33	38	43	47
Power supply		- 220-240V/50Hz/1Ph								

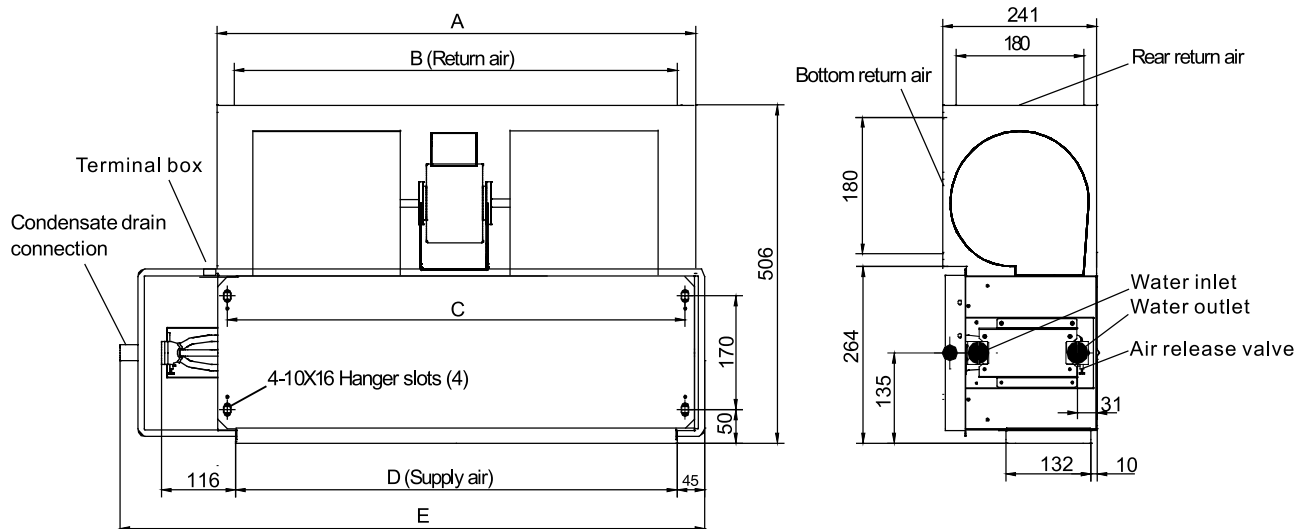

Model		CH-FDH 020K2	CH-FDH 030K2	CH-FDH 035K2	CH-FDH 045K2	CH-FDH 060K2	CH-FDH 075K2	CH-FDH 100K2	CH-FDH 110K2	CH-FDH 120K2
A (mm)		547	647	747	747	967	1267	1372	1662	1828
B (mm)		515	615	715	715	935	1235	1340	1630	1796
C (mm)		513	613	713	713	933	1233	1338	1628	1794
D (mm)		485	585	685	685	905	1205	1310	1600	1766
E (mm)		757	812	912	912	1135	1435	1540	1830	1992

WALL MOUNTED TYPE FAN COIL UNIT



- New panel supplies more choice for customs
- Multi-connection outlet pipe method: left/right/rear, more flexible for installation
- Wind direction adjustment can be in horizontal and vertical way for auto swing louver
- Built-in 3 way electromagnetic valve
- Easy maintenance has been realized as the front panel can be removed for easy access
- Remote controller with LCD display is standard, wired controller and central controller are optional
- Four-speed motor with super high speed reserved for more choice
- Eurovent certified performance.

Model		CH-FW025K2	CH-FW030K2	CH-FW040K2	CH-FW050K2	CH-FW060K2
Cooling capacity (W)	H	2630	2970	3280	4250	5000
	M	2410	2470	2830	3850	4470
	L	2160	2120	2410	3320	3970
Heating capacity(W)	H	3360	3910	4370	5810	6700
	M	3100	3260	3730	5170	6000
	L	2790	2770	3170	4430	5280
Air flow (m³/h)	H	425	510	680	850	1020
	M	360	430	580	720	870
	L	320	380	510	640	770
Sound pressure(dB (A))	H	30	35	37	39	40
	M	24	29	31	33	34
	L	20	24	26	28	29
Rated input (W)		24	37	40	50	66
Weight (kg)		13		13.3	15.8	
Power supply		- 220-240V/50Hz/1Ph				

CH-FW025K2, CH-FW030K2, CH-FW040K2

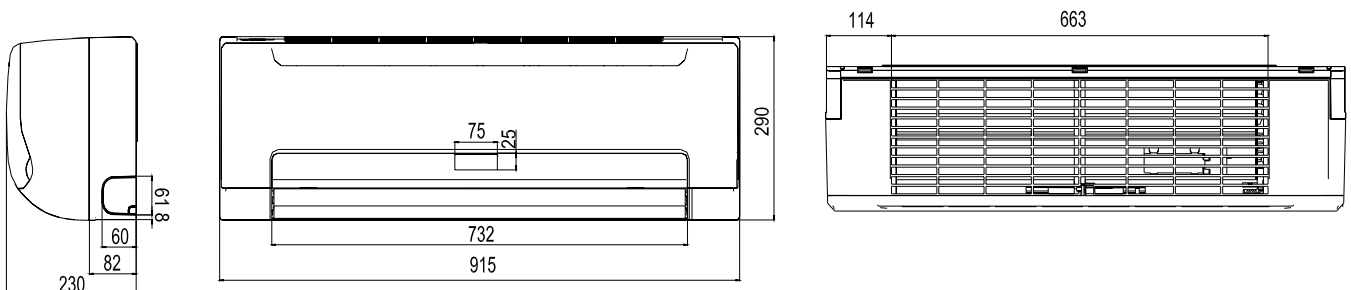

CH-FW050K2, CH-FW060K2

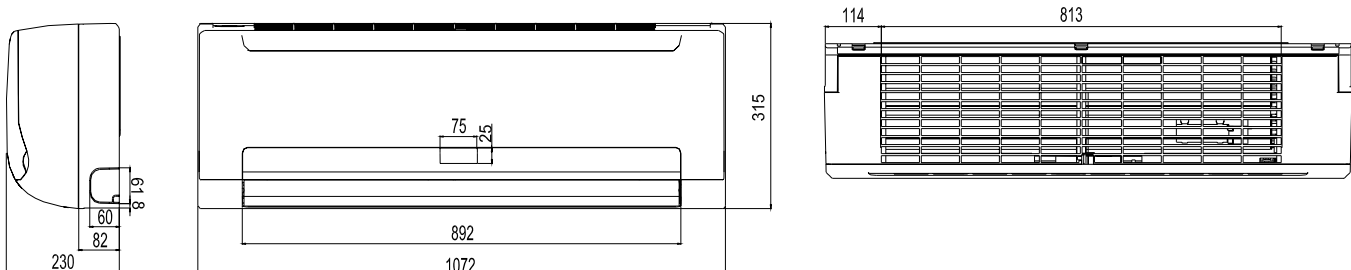

FOUR-WAY CASSETTE TYPE FAN COIL UNIT

- Chilled water/Hot water (2 pipes)
- Low height for easy installation
- Low noise fan direct driven by single phase, 3 speed permanent split capacitor motor.
- Copper tube/aluminum fin coils
- Hydrophilic aluminum fin coils coated (optional)
- Unit constructed by electrostatic galvanized sheet, providing maximum protection against corrosion
- Heavy gauge zinc coated steel drainage pan with good insulation processing, avoiding sweating and corrosion Mesh filter in regenerable polypropylene.



Model	CH-FC030K2	CH-FC040K2	CH-FC050K2	CH-FC060K2	CH-FC075K2	CH-FC085K2	CH-FC100K2	CH-FC120K2	CH-FC150K2	
Cooling capacity (W)	3000	3700	4500	5700	7000	7270	8220	10390	12900	
Heating capacity(W)	4000	5100	6000	9660	11550	12420	13850	17580	17600	
Air flow (m ³ /h)	H	510	680	850	1000	1250	1400	2000	2550	
	M	440	580	730	850	1060	1190	1700	2170	
	L	360	480	600	720	900	1010	1440	1840	
Sound pressure(dB (A))	36	42	45	45	46	47	48	49	50	
Rated input (W)	35	60	75	120	125	145	150	185	185	
Weight (kg)	Indoor unit	17.5			25		30.5		35	
	Panel	3					6			
Power supply					- 220-240V/50Hz/1Ph					

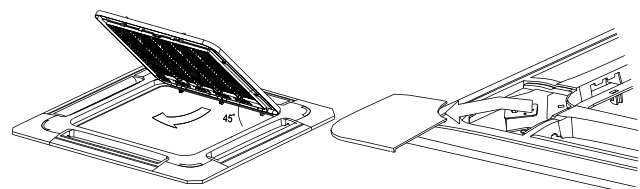
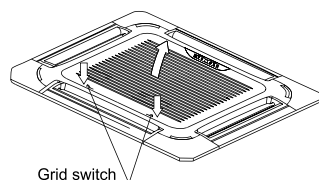
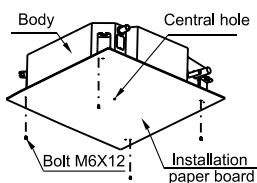
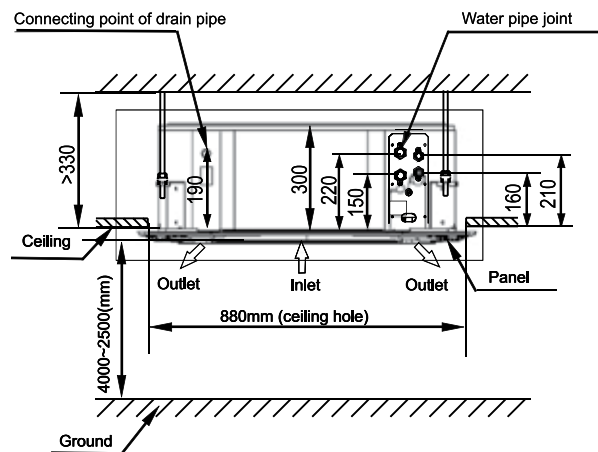
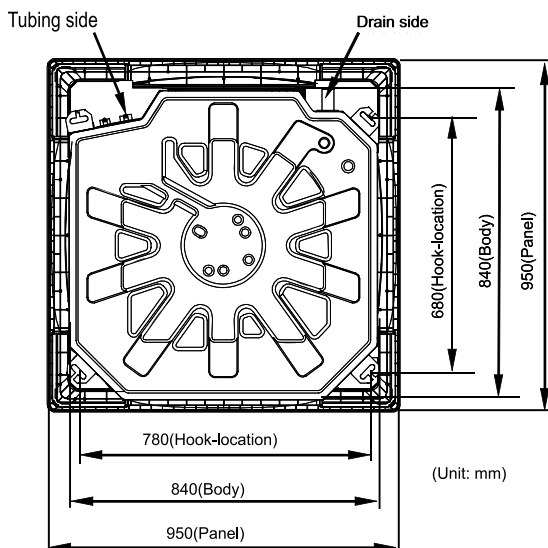

VRF CHV5 HOME

INVERTER



The newest hybrid VRF system with heat recovery and simultaneous capability: cooling / heating of indoor air, hot water supply and floor heating.

16 kW hydrobox produce with a high-efficiency plate heat exchanger;

Control by means of «CAN network control»

The area of the serviced room is increased, over 200 m².

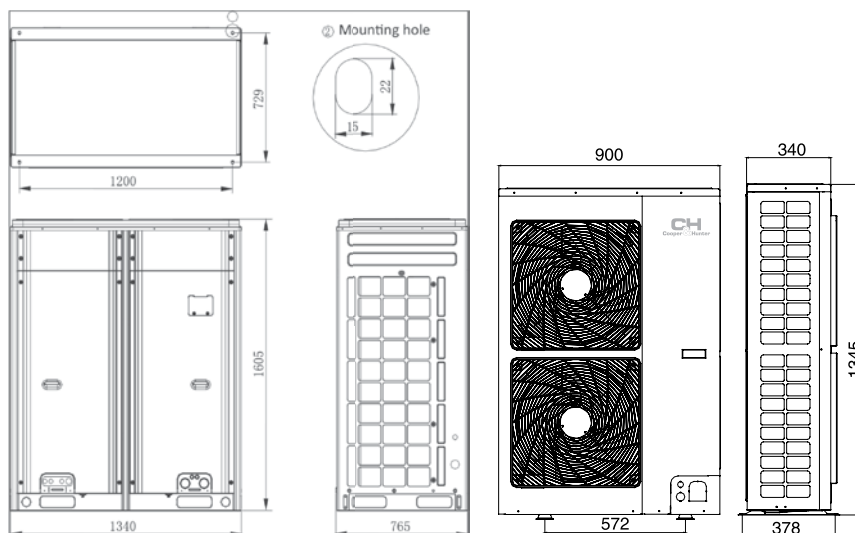

Outdoor unit

			CHV-5SHH120NK	CHV-5SHH140NK	CHV-5SHH160NK	CHV-5SHH224NK	CHV-5SHH280NK
Capacity	Cooling	kW	12.10	14.0	16.0	22.4	28
	Heating	kW	14.0	16.5	18.5	25	31.5
Power source			- 220-240V/50Hz/1Ph			- 380-415V/50Hz/3Ph	

Hot water generator

		HB16NK
Capacity range	kW	3.6-16

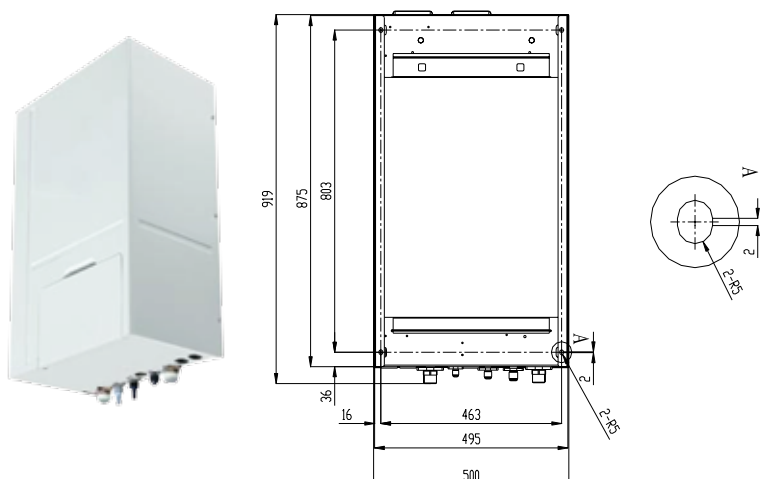

VRF SYSTEM CHV5

INVERTER



High Static Pressure
Duct Type Indoor Unit



Compact 4-way
Cassette Indoor Unit



Slim Duct
Type Indoor Unit



Low Static Pressure
Duct Type Indoor Unit



1-way Cassette
Indoor Unit



4-way Cassette
Indoor Unit



Floor-Ceiling
Type Indoor Unit



Console
Indoor Unit



Wall-mounted
Indoor Unit



Fresh Air Processing
Indoor Unit

- Inverters and motor drive on the indoor and outdoor units;
- Heat braking unit made it possible to raise IPLV up to 6,8, making it 33 % higher than the previous version;
- Patented principle of oil return (99 % of all oil do not leave the compressor!) completely removes the problem of oil starving;
- Almost 80 indoor units of 10 types: 3 standart sizes of AHU-KITs: 14kW, 28kW, 56kW;
- Maximum length of the pipeline is 1000 m;
- Elevation difference – up to 90 m: standart sizes of the outdoor units of CHV5 min: 12kW, 14kW, 16kW; standart sizes of the outdoor units of CHV5 Slim: 22.4kW, 25kW, 28kW, 33.5kW;
- Standard sizes of the outdoor units of CHV5: from 22,4 kW to 61,5 kW; Modular composition – up to 246 kW;
- Operational temperature range: from - 20°C to + 50°C;
- In CHV5 a new up-to-date CAN bus protocol is used;
- Small “USB Data Converter” can be connected to any block and using PC provides the system control, adjustment and maintenance;
- There are special modes: 9 variants of energy saving settings, noiseless operation (for outdoor unit making 22,4 kW, 45 dB), background heating (keeping +8°C) etc.;
- System engineering, turn-key project in .xls and .dwg formats are executed using CHV

NEW

VRF SYSTEM CHV5 SOLAR

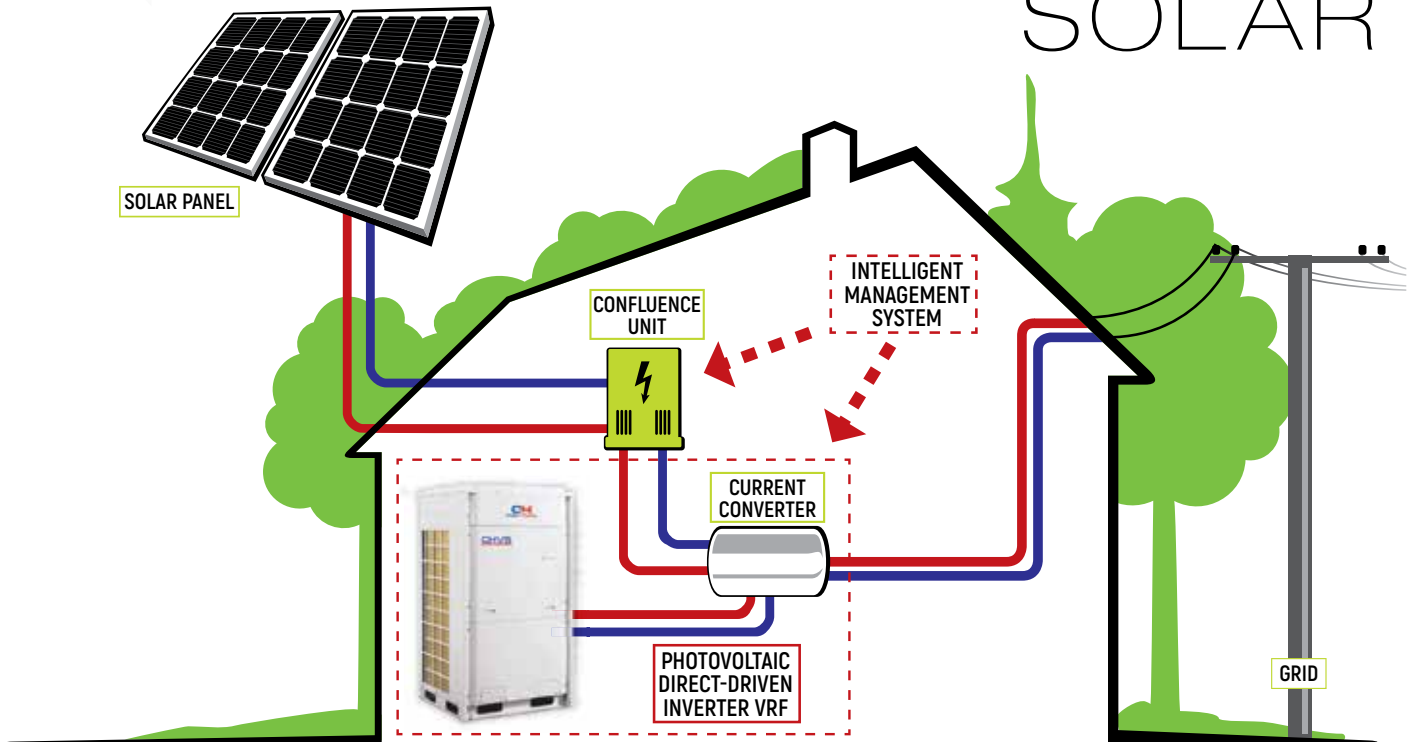

Photovoltaic direct-driven inverter VRF: all series of basic model are 22.4kW, 28.0kW, 33.5kW, combined type model is 22.4–134.0kW

Model	Cooling Capacity (kW)	Heating Capacity (kW)	Power supply	Appearance
CHV-5SL224NMX	22.4	25.0	AC source: 380-415V 3~50/60Hz DC source: 370-900Vdc	
CHV-5SL280NMX	28.0	31.5		
CHV-5SL335NMX	33.5	37.5		

ENERGY RECOVERY VENTILATION SYSTEM

- Temperature display
- Speed selection
- Weekly timer
- Bypass
(not available on models CH-HRV15K2, CH-HRV20K2, CH-HRV25K2, CH-HRV30K2)
- External ON/OFF
- Comfortable heater control
- Defrosting
- CO₂ control (Optional)
- Filter alarm
- Fault alarm
- Data memory
- Night free cooling
(not available on models CH-HRV15K2, CH-HRV20K2, CH-HRV25K2, CH-HRV30K2)
- BMS integration
- Humidity control (Optional)
- Defrosting heater control
- Working condition monitor

ON/OFF



Model		CH-HRV2K2	CH-HRV3K2	CH-HRV4K2	CH-HRV6K2	CH-HRV8K2	CH-HRV10K2	CH-HRV13K2
Airflow	(m ³ /h)	L	150	250	350	500	700	1000
		M	200	300	400	600	800	1000
		H	200	300	400	600	800	1000
External pressure	(Pa)	L	60	75	80	89	92	80
		M	70	82	85	92	96	85
		H	75	85	88	97	100	86
Enthalpy Eff.(%)	Cooling	L	60	62	62	63	57	60
		M	55	57	57	59	55	58
		H	55	57	57	59	55	58
	Heating	L	63	65	65	67	63	64
		M	59	61	60	61	57	62
		H	59	61	60	61	57	62
Temp.Eff	(%)	L	75	73	74	76	74	76
		M	70	68	69	70	68	70
		H	70	68	69	70	68	70
Noise	dB (A)	L	22	23	25	25	32	32
		M	25	27	29	31	37	36
		H	27	30	32	35	39	40
Voltage (V)		220	220	220	220	220	220	220
Current (A)		0.5	0.56	0.72	0.96	1.7	2.1	3.4
Input Power (W)		105	117	150	200	355	440	710
Net Weight (KG)		23	25	31	36	60	70	79

ON/OFF



*1 – celluloid heat exchanger



*2 – aluminum heat exchanger

Model		CH-HRV15K2*1 CH-HRV15AK2*2	CH-HRV20K2*1 CH-HRV20AK2*2	CH-HRV25K2*1 CH-HRV25AK2*2	CH-HRV30K2*1 CH-HRV30AK2*2
Airflow	(m ³ /h)	L	1000	1200	2000
		M	1500	2000	2500
		H	1500	2000	2500
External pressure	(Pa)	L	84	110	140
		M	135	132	170
		H	163	176	200
Enthalpy Eff.(%)	Cooling	L	69	65	64
		M	66	62	61
		H	66	62	61
	Heating	L	74	73	72
		M	70	71	70
		H	70	71	70
Temp.Eff	(%)	L	74	74	73
		M	71	71	70
		H	71	71	70
Noise	dB (A)	L	46	49	50
		M	49	51	52
		H	51	53	55
Voltage (V)		220	220	220	220
Current (A)		2.3/3.6/3.8	3.0/4.6/4.8	4.5/6.0/6.3	6.5/8.7/9.0
Input Power (W)		485/740/785	650/980/1020	940/1250/1300	1400/1870/1950
Net Weight (KG)		110	112	130	142

INVERTER



Model	CH-HRV1.5KDC	CH-HRV2.5KDC	CH-HRV3.5KDC	CH-HRV5KDC	CH-HRV6.5KDC	CH-HRV8KDC	CH-HRV10KDC	CH-HRV15KDC	CH-HRV20KDC
Performance									
Airflow (m³/h)	150	250	350	500	650	800	1000	1500	2000
Airflow (l/s)	43	71	100	143	186	229	286	429	571
Enth. Eff (%)	Heating	70	70	69	67	68	71	71	71
	Cooling	63	63	66	62	62	65	65	65
Temp. Eff (%)	75	75	75	75	75	75	75	75	75
Noise DB (A)	23	24	28	30	32	35	35	38	38
Power Supply	- 220-240V/50Hz/1Ph								
Input Power (W)	51	81	112	143	205	290	305	580	610
Power Cable	2x1,5mm.								
Control Cable	2x0,5mm.								
Control	Standard	Yes (7-Day Time-clock)							
	(BMS) Modbus	Yes							No
Fan Type	DC Fan Motors								
Fan Speeds (Supply)	10 Speed Fan Control								
Fan Speeds (Exhaust)	10 Speed Fan Control								
Summer Bypass	Yes (Automatic with adjustable range)								
Defrost	Yes (Automatic with adjustable range)								
CO ₂ Control	Optional controller available (On / Off control with adjustable range)								
Fan Boost Contacts	Yes (3x available connections to Contacts: Closed = Boost to High Speed)								
Fire Shutdown	Yes (1x available connection to Contact: Closed = Shutdown)								
Weight (Kg)	25	29	37	43	64	71	83	165	189
Size (WxHxD)	580x264x808	599x264x882	804x270x882	904x270x962	884x340x1222	884x388x1322	1134x388x1322	884x785x1322	1134x785x1322
Duct Size	150	150	150	200	200	250	250	300	300



STANDARD



TOUCH SCREEN OPTIONAL

Compatible models HRV	CH-HRV2...13K2 CH-HRV1.5...20KDC	CH-HRV15...30K2 CH-HRV15...30AK2	CH-HRV2...13K2 CH-HRV1.5...20KDC	CH-HRV15...30K2 CH-HRV15...30AK2
Comfortable heater control		O		O
Temperature display	OA/RA/SA/FR temp		OA/RA/SA/FR temp	
Speed selection		O		O
Weekly time		O		O
Bypass	Auto	X	Auto	X
External ON/OFF		O		O
Defrosting		O		O
CO ₂ control (Option)		O		O
Filter alarm		O		O
Fault alarm		O		O
Data memory		O		O
Night free cooling	O	X	O	X
Humidity control (Option)		O		O
BMS integration		O		O
Defrosting heater control		O		O
Working condition monitor		O		O

AHU Kit inverter for Light Commercial

TYPE: NORDIC COMMERCIAL 4

VERSION: 1.03

TECHNICAL PARAMETERS

Application	C&H NORDIC COMMERCIAL IV series (CH-IUxxNK4) + any airhandling units equipped with direct expansion air exchanger
AHU unit capacity	2,6-16kW (more with parallel connection)
Power voltage	220-240V/1Ph/50Hz (CH-IUxxNK4) 380-415V/3Ph/50Hz (CH-IUxxNM4)
Control signal setting	0-100% (0-8.5V, stepless), 3 floating contact signals master control
Control device	system (AHU control system, BMS)
Outdoor temperature operation range	-15 to 48°C (cooling), -20 to 24°C (heating)

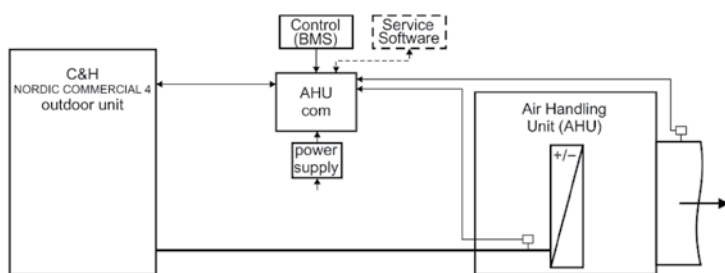

Condensing units:

- CH-IU09NK4
- CH-IU12NK4
- CH-IU18NK4
- CH-IU24NK4
- CH-IU30NK4
- CH-IU36NK4
- CH-IU42NK4
- CH-IU48NK4
- CH-IU36NM4
- CH-IU48NM4
- CH-IU60NM4



AHU-Kit for VRF CVH5

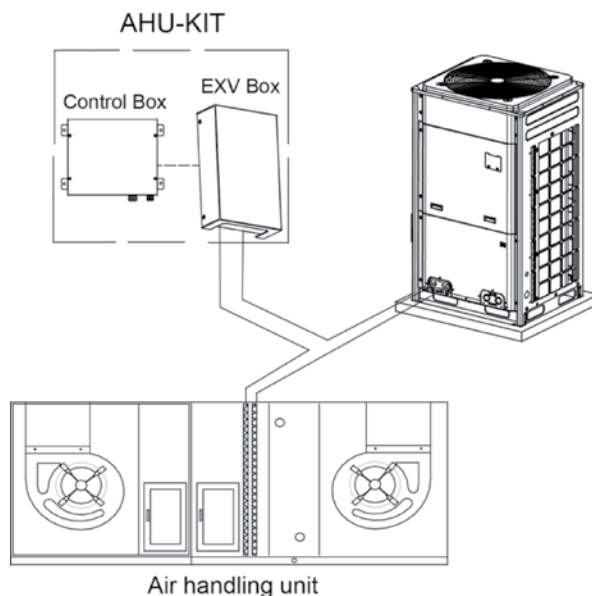

TECHNICAL PARAMETERS

Model	Max power (kW)	Installable power levels (kW)
CHV-AK140NK	14.0	9.0/11.2/14.0
CHV-AK280NK	28.0	22.4/28
CHV-AK560NK	56.0	45/50.4/56









































COMMERCIAL AIR CONDITIONERS FLOOR STANDING TYPE



- Timer;
- «Turbo» mode;
- Informative display;
- Self-diagnosis;
- Self-cleaning system;
- Autorestart;
- Display with a clock;
- Locking of the remote;
- Intelligent defrosting;
- The presence of an additional electric heater in the indoor unit of model CHF60AH-K3NNA5A

Model		CHF24AG-K3NNA5A		CHF36AH-K3NNA5A		CHF48AH-K3NNA5A		CHF60AH-K3NNA5A	
Function		COOLING	HEATING	COOLING	HEATING	COOLING	HEATING	COOLING	HEATING
Rated Voltage		- 220-240V/50Hz/1Ph		- 380-415V/50Hz/3Ph					
Total Capacity (W)		7050	7800	11000	12700	12400	13600	15530	19000
Power Input (W)		2430	2350	3920	4220	4940	4840	6190	6530
Air Flow Volume (m3/h)		11000		1700		1800		2000	
Dehumidifying Volume (l/h)		3		4.5		6		6	
EER / C.O.P (W/W)		2.9/3.32		2.81/3.01		2.51/2.81		2.51/2.91	
Indoor unit	Sound Pressure Level dB (A) (H/M/L)	48/45/42/40		51/49/47/45		52/50/48/46		54/52/50/47	
	Dimension (W/H/D) (mm)	500x1757x300				518x1870x395			
	Net Weight (kg)	40		60		63			
Outdoor unit	Sound Pressure Level dB (A) (H/M/L)	56		59				63	
	Dimension (W/H/D) (mm)	1018x840x412		1032x1250x412					
	Net Weight (kg)	69		105		110		117	
	Refrigerant Charge (kg)	R410/2.1		R410/3.2		R410/3.6		R410/4.45	

Features

	Energy Star certified		Swing mode – wide angle louvers		The Wi-Fi function module to manage the air conditioner via a Smartphone/Tablet (OS: Android, iOS)
	AHRI certified		Cooling		The evaporator of indoor unit will be blown after the unit is stopped to avoid mould
	Intertek certified		Heating		Backlight of indoor unit display
	CE certified		Dry mode – dehumidifying		"I Feel" The controller will automatically adjust the indoor temperature according to the temperature detected by the remote
	RoHS certified		I-Action Inverter Technology		Defends your home from frizzing: function "+8 degrees".
	Energy Efficiency Class		Intelligent defrost system		GREEN-FIN – anticorrosive cover of the heat exchangers
			Inverter compressor		ECO-FRESH – eletret dust filter
	Energy Class Efficiency type		LED-Display of indoor unit		CH SMART-ION Filter – new generation technology for complete purification of air
			Multi speed fan		Warranty
	Timer		Type of refrigerant		The unique technology of CH 7-SKY means the seven air purification steps
	Self-diagnostics system				Two-stage Compressor
	Auto-protection				
	Automatic restart				
	Step-less Fan Control - controlled by step-less regulation technology, the fan speed be adjust 1% to 100% between the highest and lowest speed.		Sleep mode		
			Noise Analysis Technology – noiseless operation		



COOPERANDHUNTER.COM